

420/20L



300746

Bartscher GmbH
Franz-Kleine-Str. 28
D-33154 Salzkotten
Germany

Phone: +49 5258 971-0
Fax: +49 5258 971-120
Technical Support Hotline: +49 5258 971-197
www.bartscher.com



Version: 3.0

Date of preparation: 2024-01-09

Original instruction manual

1	Safety	2
1.1	Explanation of Signal Words	2
1.2	Safety instructions.....	3
1.3	Intended Use	5
1.4	Unintended Use	5
2	General information	6
2.1	Liability and Warranty	6
2.2	Copyright Protection	6
2.3	Declaration of Conformity	6
3	Transport, Packaging and Storage	7
3.1	Delivery Check.....	7
3.2	Packaging	7
3.3	Storage	7
4	Technical Data.....	8
4.1	Technical Specifications	8
4.2	List of Components of the Appliance	9
4.3	Functions of the Appliance.....	11
5	Installation and operation	12
5.1	Installation.....	12
5.2	Benefits of Vacuum Sealing.....	13
5.3	Rules of Vacuum Sealing.....	15
5.4	Operation.....	18
6	Cleaning	27
6.1	Safety Instructions for Cleaning	27
6.2	Cleaning.....	28
7	Possible Malfunctions.....	29
8	Disposal.....	32



Read this instruction manual before using and keep it available at all times!

This instruction manual contains information about installation, operation and maintenance of the appliance and constitutes an important source of information and reference guide. The knowledge of all operational and safety instructions included in this manual is a prerequisite for safe and proper handling of the appliance. Additionally, accident prevention, occupational health and safety, and legal regulations in force in the area the appliance is used apply.

Before you start using the appliance, especially before turning it on, read this instruction manual in order to avoid personal injuries and property damages. Improper use may cause damage.

This instruction manual forms an integral part of the product and must be stored in an immediate vicinity of the appliance and be available at all times. The instruction manual should be transferred together with the appliance.

1 Safety

This appliance has been manufactured in accordance with technical standards currently in force. However, the appliance may be a source of hazards if used improperly or contrary to its intended purpose. All persons using the appliance must consider information included in this instruction manual and observe safety instructions.

1.1 Explanation of Signal Words

Important safety instructions and warning information are indicated in this instruction manual with appropriate signal words. You must strictly follow the instructions, to prevent accidents, personal injuries and property damages.



DANGER!

The signal word **DANGER** warns against hazards that lead to severe injuries or death if the hazards are not avoided.



WARNING!

The signal word **WARNING** warns against hazards that may lead to moderate or severe injuries or death if the hazards are not avoided.



CAUTION!

The signal word **CAUTION** warns against hazards that may lead to light or moderate injuries if the hazards are not avoided.

IMPORTANT!

The signal word **IMPORTANT** indicates possible property damages, which may occur if safety instructions are not observed.

NOTE!

The symbol **NOTE** indicates subsequent information and guidelines for the user on usage of the appliance.

1.2 Safety instructions

Electrical Current

- Too high a mains voltage or incorrect installation may cause electric shock.
- The appliance may be connected only if data on the rating plate correspond with the mains voltage.
- To avoid short-circuit, the appliance should be kept dry.
- If there are malfunctions during operation, disconnect the appliance from the power supply.
- Do not touch the appliance's plug with wet hands.
- Never take hold of the appliance if it has fallen into water. Immediately disconnect the appliance from the power supply.
- Any repairs or housing opening may be carried out by professionals and relevant workshops only.
- Do not transport the appliance, holding it by the power cord.
- Do not allow the power cord to come into contact with heat sources or sharp edges.
- Do not bend, pinch nor knot the power cord.
- Always completely unwind the power cord.
- Never place the appliance or other objects on the power cord.
- Always take hold of the plug to disconnect the appliance from the power supply.

- Check the power cord regularly for damage. Do not use the appliance if the power cord is damaged. If this cable is damaged, it must be replaced by customer service or a qualified electrician in order to avoid dangers.

Supervised Usage only

- Only supervised appliance may be used.
- Always remain in an immediate vicinity of the appliance.

Operating Personnel

- The appliance may only be operated by qualified personnel and trained specialist personnel.
- This appliance may not be operated by persons (including children) with limited physical, sensory or mental capabilities, nor by persons with limited experience and/or limited knowledge.
- Children should be supervised to ensure that they are not playing with or switching on the appliance.

EN

Improper Use

- Unintended or prohibited use may cause damage to the appliance.
- The appliance may only be used when its technical condition is flawless and allows for safe operation.
- The appliance may only be used when all connections are executed according to rules of law in force.
- The appliance may only be used when it is clean.
- Use only original spare parts. Never attempt to repair the appliance on your own.
- Do not introduce any changes in the appliance nor modify it.

1.3 Intended Use

As described below, every use of the appliance for a purpose differing and/or diverging from its intended standard use, is prohibited and considered to be an unintended use.

The following is an intended use:

- Vacuum sealing and marinating of suitable food products or vacuum sealing of other objects.

1.4 Unintended Use

An unintended use may lead to personal injuries or property damages caused by hazardous voltage, fire or high temperature. The appliance may only be used to perform tasks described in this instruction manual.

2 General information

2.1 Liability and Warranty

All information and instructions in this instruction manual account for legal regulations in force, current level of technical engineering knowledge as well as our expertise and experience, developed over the years. If special models or additional options are ordered, or state-of-the-art technical solutions were implemented, the actual scope of delivery of the appliance may, in some circumstances, differ from descriptions and numerous drawings in this instruction manual.

The manufacturer is not liable for any damages nor faults stemming from:

- failure to observe instructions,
- unintended use,
- technical alterations introduced by the user,
- usage of unapproved spare parts.

We reserve the right to introduce technical modifications to the product, intended for improvement of the appliance and its performance.

2.2 Copyright Protection

This instruction manual, and texts, drawings and images included in it, as well as its other components are copyright protected. It is prohibited to reproduce this instruction manual (including its excerpts), in any form and by any means, and to use and/or transfer its content to third parties without manufacturer's written permission. Violation of the above results in obligation to pay compensation. We reserve the right to claim further damages.

2.3 Declaration of Conformity

The appliance meets the currently applicable standards and guidelines of the European Union. We confirm the above in the EC Declaration of Conformity. We may provide relevant Declaration of Conformity upon request.

3 Transport, Packaging and Storage

3.1 Delivery Check

Immediately upon reception, check the delivery for completeness and possible shipping damage. In the case of visible transport damage refuse to accept the appliance or accept it conditionally. Mark and note the scope of damage in shipping documents/consignment list of the shipping company and lodge a complaint.

Concealed damage must be reported immediately upon its discovery, as compensation claims may only be filed within applicable time limits.

If you find that parts or accessories missing, please contact our Customer Service Department.

3.2 Packaging

Do not dispose of the appliance cardboard box. It may be used to store the appliance when relocating or when shipping the appliance to our service point in the case of any damages.

The packaging and its elements are made of recyclable materials. Particularly, these are: plastic films and bags, cardboard box.

When disposing of the packaging, observe applicable domestic regulations. Recyclable packaging materials should be recycled.

EN

3.3 Storage

Leave the packaging closed until installation of the appliance; observe external indications concerning method of placing and storage. Store the packaging in the following conditions only:

- in closed rooms;
- in dry and dust-free surrounding;
- away from aggressive agents;
- in a location protected against sunlight;
- in a location protected against mechanical shocks.

In the case of extended storage (over three months), make sure you check the condition of the packaging and the parts regularly. If needed, replace the packaging with a new one.

4 Technical Data

4.1 Technical Specifications

Name:	Vacuum packaging machine 420/20L
Art. No.:	300746
Material:	stainless steel, plastic
Number of seal seams:	2
Sealing rod length, in mm:	420
Vacuum pump, l/min (m ³ /hour):	20 (1,2)
Maximum vacuum, in mbars:	-900
Sealing time adjustment, levels:	2
Power supply:	0,35 kW 220-240 V 50 Hz
Dimensions (W x D x H), in mm:	500 x 395 x 140
Weight, in kg:	6,6

We reserve the right to implement technical modifications.

Version / characteristics

- Colour: silver / black
- Control: electronic
- Indicator lights: ON/OFF
- Vacuum control: electronic
- Functions:
 - Combination of vacuum packaging and sealing
 - Sealing
 - Marinating
- Digital display
- ON/OFF switch
- Lighting:
- Roll holder with integrated blade
- Clamp bar for vacuuming bags
- The set includes: 1 vacuuming film roll (40 cm x 6 m)

4.2 List of Components of the Appliance

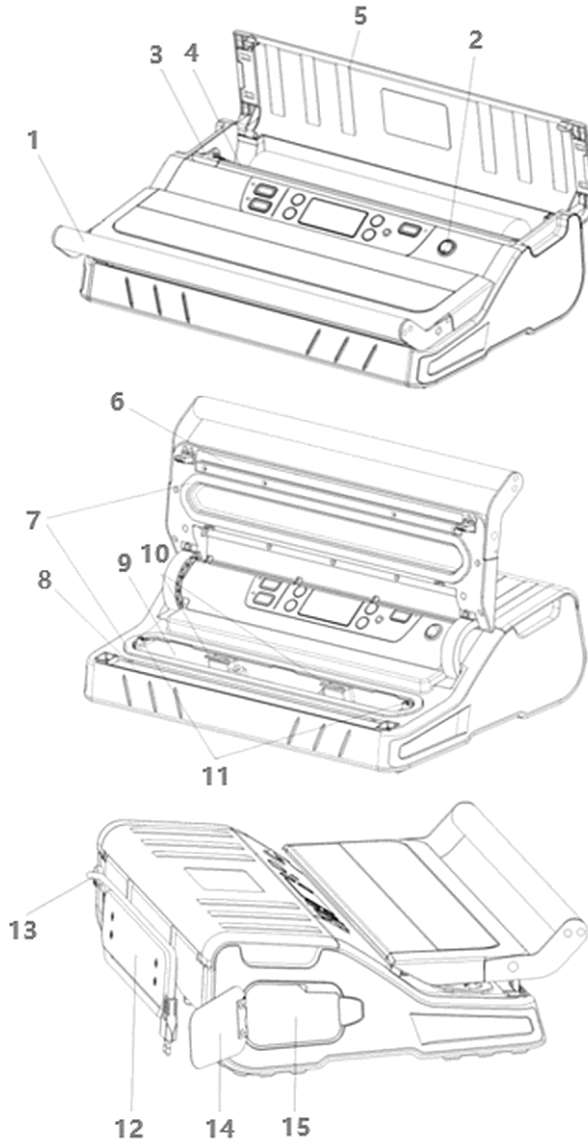

EN

Fig. 1

Description for Fig. 1

- | | |
|----------------------------|--|
| 1. Front cover with handle | 2. ON/OFF switch |
| 3. Blade | 4. Cutting rail |
| 5. Rear cover | 6. Sealing bar |
| 7. Upper + lower gasket | 8. Sealing strip |
| 9. Vacuum chamber | 10. Vacuum bag clamps |
| 11. Air-suction holes | 12. Element for winding the power cord |
| 13. Power cord | 14. Hose holder flap |
| 15. Connecting hose holder | |

Accessories (not included in the scope of delivery)

Set of vacuum sealing film rolls 220

Consists of 2 vacuum sealing film rolls

Roll width: 22 cm

Roll length: 5 m

Dimensions: W 220 x D 40 x H 40 mm

Weight: 0.46 kg

Art. No.: 300418



Set of vacuum sealing film rolls 280

Consists of 2 vacuum sealing film rolls

Roll width: 28 cm

Roll length: 5 m

Dimensions: W 280 x D 50 x H 50 mm

Weight: 0.512 kg

Art. No.: 300419



Set of vacuum sealing film rolls 400

Consists of 2 vacuum sealing film rolls

Roll width: 40 cm

Roll length: 6 m

Dimensions: W 400 x D 65 x H 65 mm

Weight: 0.86 kg

Art. No.: 300424



Technical Data

Vacuum bags G1,2L

Volume: 1.2 litres

Dimensions: 160 x 250 mm

Art. No. 300411



Vacuum bags G2,5L

Volume: 2.5 litres

Dimensions: 200 x 300 mm

Art. No. 300412



Vacuum bags G7,5L

Volume: 7.5 litres

Dimensions: 300 x 400 mm

Art. No. 300413

4.3 Functions of the Appliance

The vacuum packaging machine was designed for vacuum packaging or marinating of food products. During vacuum packaging, air is extracted from a vacuum bag, and then it is tightly sealed, thus preventing food products from perishing or slowing this process down.

5 Installation and operation

5.1 Installation

Unpacking / Positioning

- Unpack the appliance, remove all external and internal packaging elements and shipment safeguards.



CAUTION!

Choking hazard!

Prevent children from accessing package materials, for instance: plastic bags and EPS.

- If the appliance is covered with a protective film, remove it. Remove the film slowly, so no glue residues are left. Remove any glue residues with the use of a suitable solvent.
- Be careful not to damage the rating plate and warning labels fixed on the appliance.
- **Never** place the appliance in humid or wet environment.
- Place the appliance in a way making the connections easily accessible, so that they may be quickly disconnected if such a need arises.
- The appliance should be placed on surfaces that are:
 - even, with sufficient bearing capacity, resistant to water, dry and resistant to high temperatures;
 - sufficiently large, and thus enabling usage of the appliance with no problems;
 - easily accessible;
 - well ventilated.
- Maintain sufficient clearance from table edges. The appliance might turn over and fall down.
- Leave at least 10 cm clearance from flammable walls and items.

Power supply connection

- Verify if technical data of the appliance (see rating plate) correspond with the local electric power grid specification.
- Connect the appliance to a single, properly grounded mains socket with protective contact. Do not connect the appliance to a multi-socket.
- The power cord should be laid in a way preventing anyone from threading on it or tripping against it.

5.2 Benefits of Vacuum Sealing

With vacuum sealing, after removal of air, a film bag or a container are seal tight closed, and thus the process of perishing food products is stopped or delayed. Thanks to vacuum sealing, the storage period of food products is extended three- or even five-folds. The flavour and vitamins are retained.

Food products are thus protected against drying, oxidation, bacteria and mould.

Packaging with vacuum sealing is a preservation process, which is recommended for fresh food products and must be connected with low temperatures, meaning a vacuum-sealed product must be stored in a refrigerator, freezer or a chiller to obtain the best possible results.

The food products that are preserved this way may be stored for a considerably longer time than similar products but not vacuum-sealed, which usable period amounts to a few hours or a few days only.

Vacuum sealing is used for the purpose of improving organisation of work, preserving food in a healthier manner and saving money:

- it may be used for special occasions:
 - to pack food products in vacuum conditions and thus extend their usable period,
 - to pre-prepare meals for the entire week,
 - to store salads, vegetables and herbs longer (they remain crisp and fresh);
- there is a more free space in a freezer;
- food products are preserved against drying and oxidation;
- this is a simple and prolonged way of pickling (20 minutes in vacuum are enough);
- this is also a way of re-packing meat products, sausages or cheese, which were already vacuum-sealed (flavour is retained);
- it provides for saving money, as all left-overs may be stored without trouble and used later;
- all types of vegetables and fruit may be bought in season, vacuum-sealed and thus stored longer.

NOTE!

All information provided in the table below are for reference purposes only and depend on impeccable condition of a packaging, and on primary quality characteristics of food products.

CAUTION!

Perishable food products should be stored in a freezer or refrigerator. Vacuum sealing extends the fastness of food products, but does not make them canned food, that is a product that is lasting in room temperature.

Food Products Storage Periods

Storage	Food products	Temperature	Standard preservation	Vacuum sealed
In a fridge	Fresh raw meat	5 ± 3 °C	2-3 days	8-9 days
	Fresh fish / seafood	5 ± 3 °C	1-3 days	4-5 days
	Cooked meat	5 ± 3 °C	4-6 days	10-14 days
	Vegetables	5 ± 3 °C	3-5 days	7-10 days
	Fruit	5 ± 3 °C	5-7 days	14-20 days
	Eggs	5 ± 3 °C	10-15 days	30-50 days
In a freezer	Frozen meat	-16 ~ -20 °C	3-5 months	> 1 year
	Frozen fish	-16 ~ -20 °C	3-5 months	> 1 year
	Frozen seafood	-16 ~ -20 °C	3-5 months	> 1 year

Storage	Food products	Temperature	Standard preservation	Vacuum sealed
At room temperature	Bread	25 ± 2 °C	1-2 days	6-8 days
	Cookies	25 ± 2 °C	4-6 months	> 1 year
	Rice/ flour	25 ± 2 °C	3-5 months	> 1 year
	Peanuts/ stone fruit	25 ± 2 °C	3-6 months	> 1 year
	Medical materials	25 ± 2 °C	3-6 months	> 1 year
	Tea	25 ± 2 °C	5-6 months	> 1 year

5.3 Rules of Vacuum Sealing

Important indications

- Thoroughly wash your hands, as well as every tool and the entire tabletop to be used for cutting and vacuum-sealing of food.
- If possible, use gloves during processing of food products.
- Use only fresh food products for vacuum sealing.
- After vacuum-sealing immediately place perishable food products in a refrigerator or freezer; do not leave them for too long in room temperature.
- Evenly distribute vacuum-sealed packagings in a refrigerator or freezer, to let them chill or freeze rapidly.
- Food products taken out of their packagings must be unconditionally consumed before their usable date provided on their original packaging.
- Vacuum-sealed packaging extends the storage period of dry food products. Products with high fat content perish faster when they are in contact with oxygen or heat. Vacuum-sealing extends also the storage period of nuts, coconut shrimps, cereals. Store in a cool and dark place.
- Vacuum sealing does not extend the storage period of vegetables and fruit, such as bananas, apples or potatoes, unless they are peeled before vacuum-sealing.
- Some types of vegetables for example: broccoli, cauliflower or white cabbage, generate gas after vacuum-sealing. Thus, before vacuum-sealing, these vegetables should be subject to blanching and frozen after the process of vacuum-sealing.

- In order to re-seal vacuum-sealed food products that were removed from a vacuum-sealed packaging, observe recommendations for cold storing after opening for the re-storage be safe.
- Consume immediately easily perishable food products, which have been heated up, thawed or taken out of a refrigerator. Do not consume food products that were lying a few hours in open air; this pertains especially for food products prepared with the use of this sauces, stored in a vacuum-sealed packaging or in an environment without access of air.
- Soft and delicate products (fish, wild strawberries, etc.) should be pre-frozen for a night. After pre-freezing, such products may be vacuum-sealed and stored in a freezer.

CAUTION!

Vacuum sealing is not a substitute of freezing nor deep freezing!

Every perishable food product, which requires freezing before vacuum sealing must be chilled and frozen also after vacuum sealing.

Vacuum packing for the freezer

- Through thoughtful packaging the device can help to extend the freshness of meals. It is necessary to pack foodstuffs in as fresh a state as possible.
- Fragile or easily deforming foodstuffs may become damaged during the vacuum packing of the fresh product. Fragile products (meat, fish, wild strawberries, sandwiches etc.) should be initially frozen.
They may be frozen for 24 hours before the frost scorch occurs. After the initial freezing they may be vacuum packed in the bags and stored for a long time in a freezer in order to maintain their taste and nutrition values.
- In order to package liquid foodstuffs, like soups, sauces, or boiled dinners, it is necessary to first freeze them in appropriate containers and then vacuum pack them, returning them to the freezer for keeping.
- Fresh vegetables should be washed or peeled and briefly blanched in boiling water or microwave, but keeping their freshness and not allowing for overcooking. After cooling down vacuum pack in any portions.
- In order to package foodstuffs which are not frozen, it is necessary to use approx. 5cm more plastic film, because in freezing the foodstuffs expand in size. Meat and fish should be placed on a paper towel, and then vacuum packed together with the paper towel. In this manner juices from the foodstuffs are absorbed.
- Prior to packing foodstuffs such as tortilla, crepes, or hamburger patties, it is necessary to separate them with wax or baking paper. This makes it easier to later remove selected items and repack the rest for keeping in the freezer.

Vacuum packing for the refrigerator

- The meals may be prepared earlier in appropriate portions and stored as vacuum packed in the refrigerator, and then heat as required.

Vacuum packing for the food storage

- The vacuum packing may also be advantageous in case of foodstuffs which may be stored in the room temperature (coffee, flour, flour products, sugar, etc.). When such foodstuffs are not used for a few days, e.g. due to vacations, they should be protected by vacuum packing. It allows to maintain their freshness and protects them from the influence of temperature, mould, and insects.

Unfreezing of foodstuffs packed in the vacuum bags

- The vacuum packed foodstuffs like meat, fish, fruits and vegetables, or other fragile products, may be slowly unfrozen on the lowest refrigerator shelf.
- Bread and tortilla should be unfrozen in the room temperature.
- Soups and other liquid meals should be heated directly in the vacuum bag in the water bath until they are hot. Before unfreezing in the room temperature or heating in the water bath one corner of the vacuum bag should be cut in order to reduce vacuum and allow for successive steam outlet.
- The foodstuffs should be consumed soon after unfreezing. Never freeze them again.

Repacking of unpacked foodstuffs

- Many food products, like cheese or meat products, are sold in the trade vacuum packages. Their taste and freshness may be also maintained after packing by repacking in the vacuum bags.

CAUTION!

The foodstuffs removed from the package must be absolutely consumed before their expiry date, specified on the original package.

After repacking they should be stored with maximum caution and hygiene.

These indications pertain to vacuum sealing

- When vacuum-sealing food products with sharp edges or shapes, e.g. bones or dried noodles, such sharp locations should be lined with a paper towel to prevent any damages to a bag.
- In order not to have brittle food products crumble during vacuum-sealing (e.g., ladyfingers or cookies), use container to store them.

- Vacuum-sealing provides for protection of various objects. At camping site, you may preserve stocks, like matches or clothing, clean and dry. Pipe tobacco may be preserved for a long time. Also, blooming or tarnishing of silver and other collectable items may be eliminated through vacuum-sealing.

5.4 Operation



WARNING!

Hand injuries as an outcome of pinching of palms or fingers between the lid and vacuum chamber!

Be very careful when closing the lid.

Danger of burning as a result of touching hot elements of the appliance following operation!

Shortly after operation, never touch the sealing rail, sealing rod nor vacuum chamber. Wait for the appliance to cool down.

Before First Use

1. Clean the appliance and working surfaces thoroughly before each use following indications in section 6 '**Cleaning**'.
2. Dry the appliance thoroughly.

Functions of control buttons / indicators

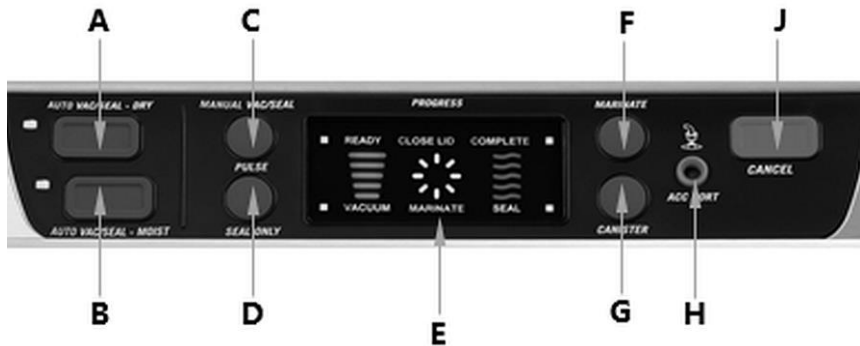

Fig. 2

A. AUTO VAC/SEAL-DRY

Automatic vacuum packaging/ dry sealing: by pressing this button the device automatically starts the vacuum packaging process, shrinking the vacuum bag until reaching the maximum vacuum and finally seals the bag during a short sealing time.

This function is intended for dry vacuum bags and food products devoid of moisture.

B. AUTO VAC/SEAL-MOIST

Automatic vacuum packaging/ moist sealing: by pressing this button the device automatically starts the vacuum packaging process, shrinking the vacuum bag until reaching the maximum vacuum and finally seals the bag during a long sealing time.

This function is intended for moist vacuum bags and food products including some moisture.

C. PULSE

Manual vacuum packaging – Pulse function: Vacuum pump sucks the air out of the vacuum bag as long as this button is pressed. You can press this button with any frequency until obtaining the desired effect.

To finish off, seal the vacuum bag.

D. SEAL ONLY

Sealing only: Vacuum is generated for a short time to ensure that the sealing strip and sealing bar are clean and will lay on top of each other. Finally, the bag is sealed during a long sealing time.

Press this button to select the following functions:

- Sealing of an open end of the vacuum bag which is fed from the foil roll;
- Stopping of the automatic function of **'Vacuum packaging & sealing'** and immediate sealing of the vacuum bag. This way, the user may control an internal vacuum inside the vacuum bag to avoid crushing delicate contents of the bag.

E. PROGRESS

Progress of individual functions is shown on the digital display.



Fig. 3



Progress of the vacuum packaging process



Progress of the sealing process



Progress of the marinating process

When the **'CLOSE LID'** indicator is on, the lid is not closed. Press the handle down to close the lid.

When the **'READY'** indicator is on, you can start the selected function.

If the **'COMPLETE'** indicator comes on, it means that the selected process has been completed.

F. MARINATE

Marinating function: Important: This function may only be used with an appropriate container for vacuum packaging and the vacuum packaging hose.

Installation and operation

During this process the lid does not need to be locked.

G. CANISTER

Container function: Using the connecting hose the vacuum is produced in the container as long as the 'CANISTER' button on the control panel is pressed down.

H. ACC PORT

Connecting hose port to carry out the vacuum packaging or marinating process in vacuum containers.

J. CANCEL

After pressing this button, the currently executed process is stopped.

Vacuum Packaging

Important advice and tips for vacuum packaging bags

- Do not leave too much air in the vacuum bag. Before sealing the vacuum bag, squeeze out as much air as possible from the bag. With too much air in the vacuum bag, the load on the vacuum pump may increase so much that the motor will not have enough power to suck all air out of the bag.
- In case of food products with sharp edges or corners, e.g. bones or dried noodles, such places should be padded with paper towels in order to avoid damaging the vacuum bag.
- Do not put too many food products in the vacuum bag. Leave enough space to allow easy insertion of an open end of the bag in the vacuum chamber.
- Always place the open end of the vacuum bag flat and evenly on the sealing strip, do not fold or bend the vacuum bag.
- Big vacuum bags which are not fully filled require longer vacuum packaging time; smaller bags may be vacuum packed faster.
- Always check the seal it should be even and have no folds.
- In case of incomplete sealing, cut off the seam and repeat the entire vacuum packaging process.

Vacuum Packaging

Selection of Vacuum Bags

Vacuum bags are available in various sizes. Select a size of the bag that is suitable for a food product that is to be sealed.

NOTE!

For vacuum packaging use only special vacuum bags (one-side corrugated, extruded bags for vacuum packaging).

Ensure that the length of the packaging bag is at least 4-5 cm longer than the food product to be preserved and include further 2 cm for each subsequent use of the vacuum packaging bag.

Making vacuum bags from foil rolls

1. To make a bag, select the foil roll of appropriate width.
2. Plug the appliance into a single socket.
3. To switch the device on, set the ON/OFF switch on the control panel to 'I' position.
4. Open the rear cover.
5. Place the foil roll in the groove intended for this purpose under the rear cover.
6. Make sure that the blade is at one of the ends (right or left) of the cutting rail.



Fig. 4

7. Extend the foil roll to the required length and place on the cutting rail.
8. Move the blade from one end to another in order to accurately and cleanly cut off the vacuum bag.



Fig. 5

9. Place the cut vacuum bag on the sealing strip up to the marked edge, and not inside the vacuum chamber.
10. Close the front cover.

Installation and operation

11. Firmly press down the front handle to lock the cover.
The acoustic signal sounds. The digital display shows '**READY**'.
The appliance is ready to carry out the the function.
12. Press the '**SEAL ONLY**' button to seal the vacuum bag.
The progress of the sealing process is shown on the digital display.
As soon as the sealing is complete, an acoustic signal sounds, and the digital display shows '**COMPLETE**'.
13. Lift the handle to open the front cover.
14. Take the ready vacuum sealing bag out of the device.
15. Check both seals.
They should have a uniform cross-section without any folds.
16. In case of incomplete sealing, cut off the seam and repeat the entire vacuum packaging process.

Air Evacuation and Sealing Mode

1. Place the food product to be packed in the vacuum bag.
2. Clean the open end of the vacuum bag and make sure there is no food or liquid residues on it.
3. Always place an open end of the vacuum bag flat and evenly spread on the sealing strip in the area of vacuum packaging, do not fold or bend the vacuum bag
4. Make sure that the air-suction holes are not covered by the vacuum bag.
5. Close the front cover.
6. Firmly press down the front handle to lock the cover.
7. To turn the device on, set the ON/OFF switch on the control panel to '**I**' position.
You will hear an acoustic signal, and '**READY**' indicator will light up.
8. Depending on the food products, select one of the functions for automatic vacuum packaging / sealing by pressing a relevant **AUTO VAC/SEAL-DRY** or **AUTO VAC/SEAL-MOIST** button on the control panel.

The air is automatically sucked out of the vacuum bag which is then sealed.
The progress of the vacuum packaging and sealing is shown on the digital display.

NOTE!

During vacuum packaging the device produces a very high vacuum in the vacuum bag. Supervise the process of vacuum packaging to avoid grinding or crushing of delicate food products.

9. To stop the process, after reaching the desired vacuum, immediately press the **'MANUAL SEAL'** button.

The vacuum pump stops the process and the appliance switches to sealing of the vacuum bag.

10. If the acoustic signal sounds and the indicator **'COMPLETE'** is on, the process has been completed.
11. Lift the handle to open the front cover.
12. Extract the sealed vacuum bag.

NOTE!

To achieve optimum vacuum packaging and sealing results, we recommend removing any leftovers of food and spilt liquids from the vacuum chamber area after each use.

13. To open the bag which has been vacuum sealed cut it with scissors.

Vacuum packaging in a vacuum bag with 'Manual vacuum packaging' / PULSE function

This function is used for vacuum packaging of delicate food products (such as tomatoes, chips and similar products), using low vacuum.

1. Place the food product to be packed in the vacuum bag.
2. Clean the open end of the vacuum bag and make sure there is no food or liquid residues on it.
3. Always place the open end of the vacuum bag flat and evenly on the sealing strip in the vacuum packaging area. **Do not fold or bend the vacuum bag.**
4. Close the front cover.
5. Firmly press down the front handle to lock the cover.
6. To turn the device on, set the ON/OFF switch on the control panel to 'I' position. You will hear an acoustic signal, and 'READY' indicator will light up.
7. Press the 'PULSE' button. As long as this button is pressed the air is being sucked out. Monitor the vacuum level in the bag. When the desired vacuum in the bag is reached, release the 'PULSE' button.

The process is stopped.

8. Finally, press the 'SEAL ONLY' button to seal the vacuum bag.

NOTE!

If the "PULSE" button is released and the "SEAL ONLY" button is not pressed within 15 seconds, the vacuum bag loses vacuum and the process is finished.

Vacuum packaging using vacuum containers

1. Fill the vacuum container with selected food products and leave at least 3 cm free from the top of the container.
2. Clean the edge of the container.
3. Put the lid on.
4. Connect the supplied vacuum packaging hose to the lid of the vacuum container and the appropriate 'ACC PORT' on the control panel of the device.
5. To turn the device on, set the ON/OFF switch on the control panel to 'I' position. You will hear an acoustic signal, and 'READY' indicator will light up.
6. Press the 'CANISTER' button to start the vacuum packaging process.

7. To make sure that air was evacuated from between the lid and the vacuum container, press the lid down at the beginning of the sealing process.

The device stops automatically when the sufficient vacuum has been reached in the vacuum container. The vacuum packaging process is finished.

8. Close the lid lock.
9. To check the vacuum packaging, simply pull the lid up. It must not move.
10. Disconnect the vacuum packaging hose from the vacuum container and from the appliance.

NOTE!

When moist food products are packed in the vacuum container, the moisture may gather on the vacuum hose port.

Clean the port after each use.

WARNING!

Use only appropriate vacuum containers and observe manufacturer's instructions regarding opening and closing of the vacuum containers.

EN

Vacuum Marinating Mode

Marinating in the vacuum container

1. Fill the vacuum container with selected food products and leave at least 3 cm free from the top of the container.
2. Clean the edge of the container.
3. Put the lid on.
4. Connect the supplied vacuum packaging hose to the lid of the vacuum container and the appropriate **'ACC PORT'** on the control panel of the appliance.
5. To turn the device on, set the ON/OFF switch on the control panel to **'I'** position. You will hear an acoustic signal, and **'READY'** indicator will light up.
6. Press the **'Marinate'** button to start the marinating process.
7. To make sure that the vacuum container is air-tight, press the lid down at the beginning of the process.

The progress of the process is shown on the digital display.

As soon as the air suction is completed, the air is automatically released.

This concerns 1 work cycle, the appliance makes in total 5 work cycles.

The marinating process takes approx. 6 minutes.

WARNING!

During the marinating process do not press any buttons, not to interrupt the entire process.

After the marinating process is complete, the '**Complete**' indicator lights up on the digital display.

8. To check the vacuum, simply pull the container lid. It must not move.
9. Press down the container lid or connecting hose on the '**ACC PORT**', to make sure that no moisture escapes.
10. Pull back the connecting hose from the container and the appliance.
11. Disconnect the hose and make sure that no air escapes through the gaps between the cables.

6 Cleaning

6.1 Safety Instructions for Cleaning

- Before cleaning, disconnect the appliance from the power supply.
- Leave the appliance to cool down completely.
- Make sure water does not enter the appliance. Do not immerse the appliance in water or other liquids during cleaning. Do not clean the appliance with a pressurized water jet.
- Do not use any sharp or pointed, nor metal implements (knife, fork, etc.). Sharp or pointed implements may damage the appliance, and when in contact with live parts, they may cause electric shock.
- For cleaning, do not use any scouring agents that contain solvents nor corrosive cleaning agents. They may damage the surface.

6.2 Cleaning

External Side of the Appliance

1. Clean the appliance daily after each use, or more frequently if needed.
2. Clean external surfaces of the appliance before use or after use, using a cloth or sponge and a mild washing agent.
3. Wipe with a clean cloth.
4. Dry all cleaned surfaces thoroughly.

Internal Side of the Appliance

1. Use a paper towel if left-over food products or liquids accumulate in the vacuum chamber, or on the sealing strip or sealing rod.
2. Wipe the vacuum chamber with a soft, damp cloth.
3. Thoroughly dry the vacuum chamber.

WARNING!

Foam gaskets around the vacuum chamber must be completely dry prior to the assembly.

Take care not to damage the gaskets, and reinstall them in the original position to ensure that vacuum does not escape.

EN

Vacuum bags

1. Wash vacuum packaging bags in warm water with a mild cleaning agent.
2. Rinse in fresh water.
3. Then, thoroughly dry the vacuum packaging bags using a lint-free cloth.

CAUTION!

In order to avoid food poisoning, do not reuse vacuum packaging bags used for storing raw meat, fish or fatty food products.

Vacuum containers

1. Clean the vacuum container in warm water with a mild cleaning agent.
2. Rinse vacuum container with fresh water.
3. Wipe the vacuum container with a soft, damp cloth only.
4. Before next use make sure that the accessories are completely dry.

HINT!

Vacuum container (not the lid!) is dishwasher safe, and can be washed in the upper area of the dishwasher.

Possible Malfunctions

WARNING!

Vacuum container and the lid are not suitable for use in a microwave oven or a freezer.

7 Possible Malfunctions

The table below contains descriptions of possible causes and solutions to malfunctions or errors during operation of the appliance. When malfunction cannot be removed, contact the technical service.

In such a case, provide article number, model name and serial number. These data may be found in the rating plate.

Malfunction	Possible cause	Solution
Appliance does not work	No power	Check and restore the electric power supply
	The appliance is not connected to the power supply	Insert the plug into the mains socket
	Damaged connection cable	Contact the service company
	ON/OFF switch is not pressed	Make sure that the ON/OFF switch is properly pressed
During vacuum packaging process, the appliance does not automatically switch to sealing	Deformed lower gasket	Replace the gasket and try again
	The vacuum bag was not placed correctly on the sealing strip	To ensure proper sealing, the open end of the vacuum bag must remain entirely within the vacuum chamber.

Malfunction	Possible cause	Solution
During vacuum packaging process, the appliance does not automatically switch to sealing	Air-suction hole is covered with the vacuum bag	Properly position the vacuum bag
	Too many products in the vacuum bag	Remove some food products, clean the edge of the vacuum bag and restart the vacuum packaging process
	Vacuum bag is damaged	Use a new vacuum bag and restart the vacuum packaging process Alternatively, put paper towel on the sharp edges of the contents.
Appliance does not generate vacuum in the vacuum chamber	The vacuum bag was not placed correctly on the sealing strip	To ensure proper vacuum packaging, the open end of the vacuum bag must remain entirely within the vacuum chamber.
	Air-suction hole is covered with the vacuum bag	Properly position the vacuum bag
	The edge of the vacuum bag is soiled with liquid, oil or crumbs.	Clean the edge of the vacuum bag and restart the vacuum packaging process
	The edge of the vacuum bag is wrinkled	Remove excess food products, smooth out the edge of the vacuum bag and restart the vacuum packaging process
	The contents of the vacuum bag have sharp edges	Wrap the sharp edges of the contents in a paper towel.

Possible Malfunctions

Malfunction	Possible cause	Solution
Expanded vacuum bag after the vacuum packaging process	The packaged food is a perishable product	All perishable products must be frozen or refrigerated after the vacuum packaging process, to be suitable for consumption longer
	Sealed fruit or vegetables are not fresh	Please, remember that fresh fruit or vegetables after the vacuum packaging process must not be stored in a room temperature, they should be stored in a cool place
No vacuum inside the vacuum container	The hose for vacuum packaging is not properly connected to the vacuum container lid and the ' ACC PORT ' on the appliance	Properly connect the hose for vacuum packaging to the vacuum container lid and the ' ACC PORT ' on the appliance
	The knob on the vacuum container is not switched to sealing position	Press down the lid on the vacuum container or the hose connection on the lid at the beginning of the vacuum packaging process to prevent the lid gasket from falling out.
	Contaminated edge of the vacuum container and lid gasket.	Clean the edge of the vacuum bag and lid gasket, and restart the vacuum packaging process
	The vacuum container or the lid is damaged or broken	Exchange the accessories

8 Disposal

Electrical Appliance



Electric appliances are marked with this symbol. Electrical appliances must be disposed of and recycled in a correct and environmentally friendly manner. You must not dispose of electric appliances with household waste. Disconnect the appliance from the power supply and remove power cord from the appliance.

Electrical appliances should be returned to designated collection points.