

**46**



**700183**

Bartscher GmbH  
Franz-Kleine-Str. 28  
D-33154 Salzkotten  
Germany

Phone: +49 5258 971-0

Fax: +49 5258 971-120

**Technical Support Hotline:** +49 5258 971-197

[www.bartscher.com](http://www.bartscher.com)



Version: 1.0

Date of preparation: 2023-02-17

---

## Original instruction manual

1	Safety .....	2
1.1	Explanation of Signal Words .....	2
1.2	Safety instructions.....	3
1.3	Intended Use .....	6
1.4	Unintended Use .....	6
2	General information .....	7
2.1	Liability and Warranty .....	7
2.2	Copyright Protection .....	7
2.3	Declaration of Conformity .....	7
3	Transport, Packaging and Storage .....	8
3.1	Delivery Check.....	8
3.2	Packaging .....	8
3.3	Storage .....	8
4	Technical Data.....	9
4.1	Technical Specifications .....	9
4.2	Functions of the Appliance.....	10
4.3	List of Components of the Appliance .....	11
5	Installation and operation .....	12
5.1	Installation.....	12
5.2	Operation .....	16
6	Cleaning and Maintenance .....	18
6.1	Safety Instructions for Cleaning .....	18
6.2	Cleaning.....	18
6.3	Maintenance .....	19
7	Possible Malfunctions.....	20
8	Disposal.....	22



**Read this instruction manual before using and keep it available at all times!**

This instruction manual contains information about installation, operation and maintenance of the appliance and constitutes an important source of information and reference guide. The knowledge of all operational and safety instructions included in this manual is a prerequisite for safe and proper handling of the appliance. Additionally, accident prevention, occupational health and safety, and legal regulations in force in the area the appliance is used apply.

Before you start using the appliance, especially before turning it on, read this instruction manual in order to avoid personal injuries and property damages. Improper use may cause damage.

This instruction manual forms an integral part of the product and must be stored in an immediate vicinity of the appliance and be available at all times. The instruction manual should be transferred together with the appliance.

## 1 Safety

This appliance has been manufactured in accordance with technical standards currently in force. However, the appliance may be a source of hazards if used improperly or contrary to its intended purpose. All persons using the appliance must consider information included in this instruction manual and observe safety instructions.

### 1.1 Explanation of Signal Words

Important safety instructions and warning information are indicated in this instruction manual with appropriate signal words. You must strictly follow the instructions, to prevent accidents, personal injuries and property damages.



**DANGER!**

The signal word **DANGER** warns against hazards that lead to severe injuries or death if the hazards are not avoided.



### **WARNING!**

The signal word **WARNING** warns against hazards that may lead to moderate or severe injuries or death if the hazards are not avoided.



### **CAUTION!**

The signal word **CAUTION** warns against hazards that may lead to light or moderate injuries if the hazards are not avoided.

### **IMPORTANT!**

The signal word **IMPORTANT** indicates possible property damages, which may occur if safety instructions are not observed.

### **NOTE!**

The symbol **NOTE** indicates subsequent information and guidelines for the user on usage of the appliance.

## 1.2 Safety instructions

### Electrical Current

- Too high a mains voltage or incorrect installation may cause electric shock.
- The appliance may be connected only if data on the rating plate correspond with the mains voltage.
- To avoid short-circuit, the appliance should be kept dry.
- If there are malfunctions during operation, disconnect the appliance from the power supply.
- Do not touch the appliance's plug with wet hands.
- Never take hold of the appliance if it has fallen into water. Immediately disconnect the appliance from the power supply.
- Any repairs or housing opening may be carried out by professionals and relevant workshops only.
- Do not transport the appliance, holding it by the power cord.
- Do not allow the power cord to come into contact with heat sources or sharp edges.
- Do not bend, pinch nor knot the power cord.

- Always completely unwind the power cord.
- Never place the appliance or other objects on the power cord.
- Always take hold of the plug to disconnect the appliance from the power supply.
- Check the power cord regularly for damage. Do not use the appliance if the power cord is damaged. If this cable is damaged, it must be replaced by customer service or a qualified electrician in order to avoid dangers.

### **Fire hazard / flammable materials hazard / explosion hazard!**

- Do not use any electric devices in the appliance.
- Do not store nor use petrol or other flammable liquids and gases in the vicinity of this or any other appliance. Those gases may cause fire or explosion hazard.
- Do not put into the appliance any explosive materials, like sprays filled with flammable propellants. Contents of containers filled with flammable gases and liquids may leak in low temperatures, and the contents may catch fire from sparks generated by an electric appliance. Explosion hazard!
- In the case of coolant leakage, pull the plug from the socket. Remove all sources of ignition in the vicinity, ventilate room and contact technical service. Avoid coolant getting in contact with eyes, as it may cause serious eye damage.
- Never use any flammable liquids for cleaning the appliance or its parts. Gases released may cause fire or explosion hazard.
- In the case of fire, disconnect the appliance from the power supply before attempting adequate fire-extinguishing actions.
- Never attempt to extinguish fire with water if the appliance is connected to the power supply. Following extinction of fire, ensure sufficient fresh air inflow.
- Defrosting process may not be sped up with mechanical means or heat energy sources (candles or heaters) nor with any other means. Vapour produced may cause short-circuit and too high temperatures may damage the appliance.
- All ventilation slots should not be obstructed during operation.
- Never attempt to damage cooling installation of the appliance.

## Safety

---

### Operating personnel

- This appliance is not intended to be used by persons (including children) with limited physical, sensory or mental capabilities, nor by persons with limited experience and/or limited knowledge.
- Children should be supervised to ensure that they are not playing with or switching the appliance on.
- Cleaning and user maintenance may not be performed by children.
- Children aged 3 to 8 may load and unload the refrigerator.

### Improper Use

- Unintended or prohibited use may cause damage to the appliance.
- The appliance may only be used when its technical condition is flawless and allows for safe operation.
- The appliance may only be used when all connections are executed according to rules of law in force.
- The appliance may only be used when it is clean.
- Use only original spare parts. Never attempt to repair the appliance on your own.
- Do not introduce any changes in the appliance nor modify it.
- Do not drill hole in the appliance nor install any objects on it.
- Do not place any heavy objects on the appliance.

## 1.3 Intended Use

As described below, every use of the appliance for a purpose differing and/or diverging from its intended standard use, is prohibited and considered to be an unintended use.

The following is an intended use:

- Cooling and preparation of suitable beverages and snacks.

The appliance is intended for operation in maximum ambient temperature of 25°C and relative humidity of 60%.

## 1.4 Unintended Use

An unintended use may lead to personal injuries or property damages caused by hazardous voltage, fire or high temperature. The appliance may only be used to perform tasks described in this instruction manual.

The following is an unintended use:

- Storing flammable or explosive objects and liquids, such as ether, petroleum or adhesives;
- Storing explosive materials, like sprays filled with flammable propellants;
- Storing pharmaceutical products or preserved blood;
- Storing live pets.



## 2 General information

### 2.1 Liability and Warranty

All information and instructions in this instruction manual account for legal regulations in force, current level of technical engineering knowledge as well as our expertise and experience, developed over the years. If special models or additional options are ordered, or state-of-the-art technical solutions were implemented, the actual scope of delivery of the appliance may, in some circumstances, differ from descriptions and numerous drawings in this instruction manual.

The manufacturer is not liable for any damages nor faults stemming from:

- failure to observe instructions,
- unintended use,
- technical alterations introduced by the user,
- usage of unapproved spare parts.

We reserve the right to introduce technical modifications to the product, intended for improvement of the appliance and its performance.

The warranty period for this appliance is 24 months, counted from the purchase date.

EN

### 2.2 Copyright Protection

This instruction manual, and texts, drawings and images included in it, as well as its other components are copyright protected. It is prohibited to reproduce this instruction manual (including its excerpts), in any form and by any means, and to use and/or transfer its content to third parties without manufacturer's written permission. Violation of the above results in obligation to pay compensation. We reserve the right to claim further damages.

### 2.3 Declaration of Conformity

The appliance meets the currently applicable standards and guidelines of the European Union. We confirm the above in the EC Declaration of Conformity. We may provide relevant Declaration of Conformity upon request.

## 3 Transport, Packaging and Storage

### 3.1 Delivery Check

Immediately upon reception, check the delivery for completeness and possible shipping damage. In the case of visible transport damage refuse to accept the appliance or accept it conditionally. Mark and note the scope of damage in shipping documents/consignment list of the shipping company and lodge a complaint. Concealed damage must be reported immediately upon its discovery, as compensation claims may only be filed within applicable time limits.

If you find that parts or accessories missing, please contact our Customer Service Department.

### 3.2 Packaging

Do not dispose of the appliance cardboard box. It may be used to store the appliance when relocating or when shipping the appliance to our service point in the case of any damages.

The packaging and its elements are made of recyclable materials. Particularly, these are: plastic films and bags, cardboard box.

When disposing of the packaging, observe applicable domestic regulations. Recyclable packaging materials should be recycled.

### 3.3 Storage

Leave the packaging closed until installation of the appliance; observe external indications concerning method of placing and storage. Store the packaging in the following conditions only:

- in closed rooms;
- in dry and dust-free surrounding;
- away from aggressive agents;
- in a location protected against sunlight;
- in a location protected against mechanical shocks.

In the case of extended storage (over three months), make sure you check the condition of the packaging and the parts regularly. If needed, replace the packaging with a new one.

## 4 Technical Data

### 4.1 Technical Specifications

<b>Name:</b>	<b>Glass-doored refrigerator 46</b>
Art. No.:	<b>700183</b>
Material:	galvanized steel sheet
Inner material:	plastic
Volume, in l:	46
Temperature range, min.–max., in °C:	4 - 18
Temperature control, levels:	5
Ambient temperature, max., in °C:	25
Coolant, amount in kg:	R600a / 0,018
Climate class:	N
Energy efficiency class:	D (EU Nr. 2019/2024)
Energy consumption, in kWh/year:	329
Number of doors:	1
Number of shelves:	1
Shelf dimensions (W x D), in mm:	365 x 165
Connected load:	0,085 kW   220-240 V   50 Hz
Dimensions (W x D x H), in mm:	432 x 484 x 516
Weight, in kg:	15,0

We reserve the right to implement technical modifications.

### Version / Characteristics

- Colour: black
- Cooling: compressor
- Control: knob
- Thermostat
- Automatic defrost function
- Evaporation of condensed water
- Shelf type: stainless steel, grate
- Height-adjustable shelves
- Door type: leaf door, glass
- Front pane: cased / framed
- Right-hand side door, with the possibility for door hinge to be changed
- Type of glazing:
  - single glazing
  - safety glass
- Insulation: cyclopentane, 28 mm

EN

More information on the appliance is available in our website [www.bartscher.com](http://www.bartscher.com) or, pursuant to the Regulation (EU) 2019/2024, in our product data base at <https://energy-label.ec.europa.eu/>. Enter article number for a given model.

## 4.2 Functions of the Appliance

The compact glass doored refrigerator has been designed for cooling and storage of suitable beverages and food products in packages or containers.

Thanks to the height-adjustable shelves, it is possible to load it according to your needs. Also, in the self-service area of kiosks, snack bars or petrol stations, the appliance is an ideal solution for storing small refrigerated food items in a small space.

### 4.3 List of Components of the Appliance

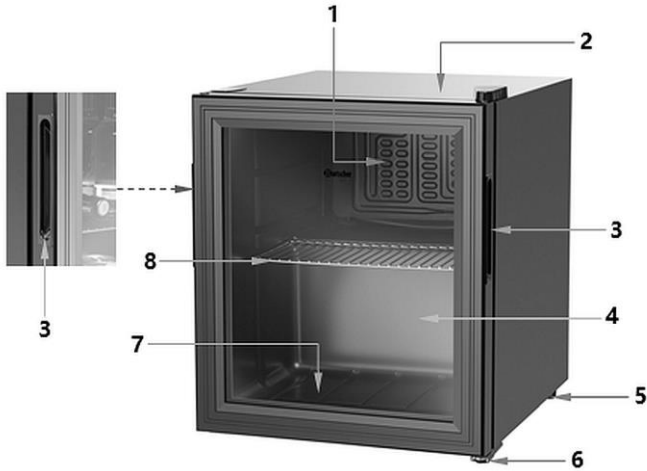

#### Rear view

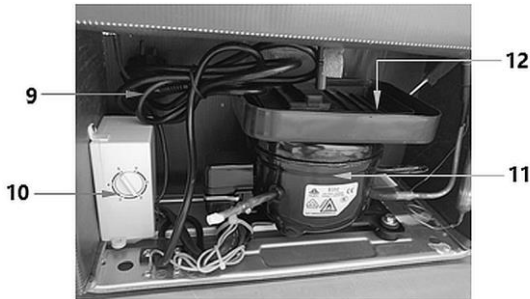

Fig. 1

- |                                       |   |
|---------------------------------------|---|
| 1. Rear panel with temperature sensor | 2. Housing                              |
| 3. Door handle recess (2 pcs)         | 4. Appliance door                       |
| 5. Rear mounting rail                 | 6. Front leg (2 pcs), height-adjustable |
| 7. Bottom display area                | 8. Grate (shelf)                        |
| 9. Power cord                         | 10. Temperature controller              |
| 11. Compressor                        | 12. Condensed water drip tray           |

EN

## 5 Installation and operation

### 5.1 Installation

#### Unpacking / Positioning

- Unpack the appliance, remove all external and internal packaging elements and shipment safeguards.



#### CAUTION!

##### Choking hazard!

Prevent children from accessing package materials, for instance: plastic bags and EPS.

- If the appliance is covered with a protective film, remove it. Remove the film slowly, so no glue residues are left. Remove any glue residues with the use of a suitable solvent.
- Be careful not to damage the rating plate and warning labels fixed on the appliance.
- **Never** place the appliance in humid or wet environment.
- Place the appliance in a way making the connections easily accessible, so that they may be quickly disconnected if such a need arises.
- The appliance should be placed on surfaces that are:
  - even, with sufficient bearing capacity, resistant to water, dry and resistant to high temperatures;
  - sufficiently large, and thus enabling usage of the appliance with no problems;
  - easily accessible;
  - well ventilated.
- Do not place the appliance in direct sunlight or in the vicinity of heat sources (cooker, radiator, heating devices, etc.). Heat sources may negatively affect power consumption, and restrict functions of the appliance, too.
- The appliance must not come into contact with heating, gas and sewage pipes or touch other electrical appliances.
- Place the appliance in a well-ventilated and dry room; its ambient temperature should correspond to the climate class for which the appliance is intended. The climate class is indicated on the rating plate (inside or at the back of the appliance) and in the **'Technical data'** section of this manual.
- Do not use the appliance in unheated rooms nor on a balcony.

## Installation and operation

- In order to avoid damage to the compressor, do not tilt the appliance more than 30° when positioning or transporting it.
- If the appliance is to be relocated, follow the instructions below:
  - disconnect the plug from the socket;
  - take out contents of the appliance;
  - tape firmly all loose elements in the internal chamber and tape the door;
  - the appliance may only be transported in vertical position.

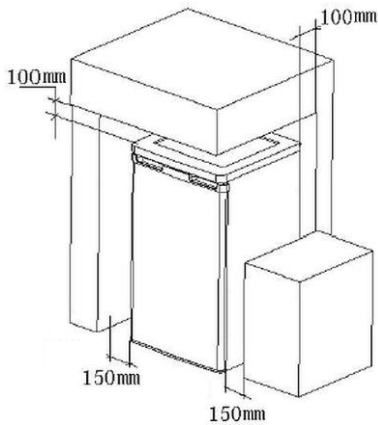

1. Ensure free circulation at the rear and top of the appliance.
2. Maintain the following minimum clearances from walls and other objects:
  - left- and right-hand side: 150 mm
  - rear: 100 mm
  - from the top: 100 mm

If maintaining the above-mentioned minimum clearances is not possible, fix a suitable insulation plate for it to reflect heat radiation.

Fig. 2

### ATTENTION!

If the provided clearance values are not observed, the power consumption rises or the compressor overheats.



Fig. 3

3. If necessary, level the appliance by rotating the two height-adjustable feet at the front bottom of the appliance (Fig. 4):
  - counter-clockwise, to raise the front part of the appliance,
  - clockwise, to lower the appliance.

### NOTE!

**If the refrigerator is not installed horizontally, the door will not close properly and the refrigeration compartment will not be airtight.**

**The door seal must provide a proper seal when the door is closed.**

4. Remove adhesive tapes from the appliance.

### Changing the Hinge Side

The hinges may be changed from right to left, as needed.

#### ATTENTION!

**Before replacing the door hinges, set the temperature controller to OFF (0) position and remove the power cord from the socket.**

**Do not place the appliance in horizontal position in order to change the door's hinge side.**

When replacing the door hinges, follow the instructions:

1. Tilt the appliance backwards (max. 45°) and support it well.
2. Unscrew the left-hand side front adjustable leg from the base.
3. Loosen the screws on the bottom of the appliance and remove the lower door hinge.
4. Fit the lower door hinge on the opposite side and tighten with screws.
5. Attach the removed adjustable leg on the opposite side.
6. Place the appliance in upright position again.
7. Remove the door hinge cap at the top of the appliance.
8. Loosen the screws and remove the upper door hinge.
9. Place the upper door hinge on the opposite side and tighten with screws.
10. Re-fix the door hinge cap.
11. Ensure that the door is in the upright position and can be easily closed.



### **NOTE!**

**After changing the door hinge, the door seal may come loose.  
Ensure that the seal is properly secured to the door.**

### **Power supply connection**

- Verify if technical data of the appliance (see rating plate) correspond with the local electric power grid specification.
- Connect the appliance to a single, properly grounded mains socket with protective contact. Do not connect the appliance to a multi-socket.
- The power cord should be laid in a way preventing anyone from threading on it or tripping against it.
  
- After transport, wait at least 8 hours before connecting the appliance to the power supply.
- If during installation the appliance was tilted by more than 30°, wait for at least 4 hours before connecting the appliance to power supply.

### **ATTENTION!**

**Otherwise, the compressor may malfunction.**

- After switching off (for cleaning, repair, re-location, etc.), the appliance may be switched back on to the power supply no earlier than after 15 minutes.
- Ensure that the plug is accessible after installing the appliance.
- Ensure that the mains plug is not crushed or damaged by the rear of the appliance.

## 5.2 Operation

### Tips for the User

- Shelves may be positioned at various heights. Arrange them adequately to the size of beverage containers, so that the inner space is used optimally.
- Beverages or snacks should be arranged on the shelves or door shelves so that proper distances between them allow for sufficient air circulation inside the appliance. Insufficient distances hinder the cooling effect.
- To limit loss of cold air minimize the opening time of door during operation. Do not open the door too frequently.
- If the appliance is switched off for a longer period of time, the door of the refrigerator should remain open.

### Appliance Preparation

1. Before the first use, clean the appliance and accessories thoroughly, following indications in section 6 '**Cleaning and Maintenance**'.
2. To end with, dry the appliance and accessories thoroughly.
3. Introduce the shelf into the appliance at the selected height.

EN

### Appliance Operation

1. Plug the appliance into a suitable single socket.



The internal temperature is set using the temperature controller. It is located at the back of the appliance.

The following settings are available:

- 0 – OFF
- 1 – max. temperature setting
- 5 – min. temperature setting

Fig. 4

#### NOTE!

**To save energy and avoid wasting food, the temperature controller should be set as follows:**

- levels 1–2 in winter
- levels 4–5 in summer
- level 3 in intermediate seasons

2. When starting the appliance for the first time, first set the temperature to the highest level (5).
3. After 20 minutes, set the temperature control to medium level (3).
4. Place suitable beverages or snacks on the shelf or on the bottom display area.
5. Close the appliance door.

### Automatic Defrosting

The refrigerator defrosts automatically.

Ice droplets that form at the inner back wall of the refrigerator melt during compressor breaks, and the melting water flows through the drain opening in the condensation water collection trough (A) to the condensation water drip tray on the compressor, where it evaporates.

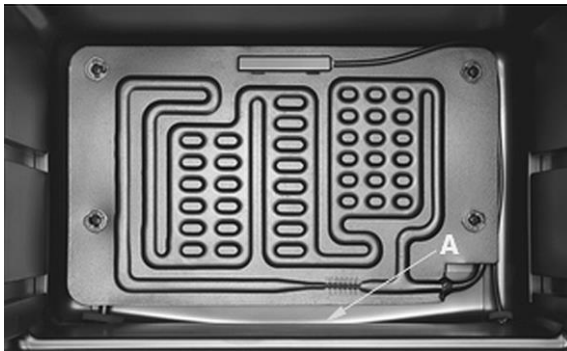

Fig. 5

EN

### Switching the Appliance OFF

1. If the appliance is not used any more, rotate the temperature controller to '0' position (10, Fig. 1).
2. Disconnect the appliance from power supply (pull the plug out).

## 6 Cleaning and Maintenance

### 6.1 Safety Instructions for Cleaning

- Before cleaning, disconnect the appliance from the power supply.
- Leave the appliance to cool down completely.
- Make sure water does not enter the appliance. Do not immerse the appliance in water or other liquids during cleaning. Do not clean the appliance with a pressurized water jet.
- Do not use any sharp or pointed, nor metal implements (knife, fork, etc.). Sharp or pointed implements may damage the appliance, and when in contact with live parts, they may cause electric shock.
- For cleaning, do not use any scouring agents that contain solvents nor corrosive cleaning agents. They may damage the surface.

### 6.2 Cleaning

1. Clean the appliance regularly.
2. Remove all objects from the appliance and store them temporarily in a cool room.
3. Remove the shelf from the appliance.
4. Clean the shelf with mild washing agent and soft cloth or sponge in warm water.
5. Rinse the shelf with fresh water and dry thoroughly with soft cloth.
4. Internal surfaces of the appliance and all plastic elements should be protected against fats, acids, sauces. If, nonetheless, they reach the surface, clean the affected place immediately with warm water and a mild cleaning agent.

#### **ATTENTION!**

**Never use hot water to clean the appliance.**

5. The drain opening on the back wall of the cooling chamber should be cleaned regularly with the provided cleaning tool.
6. Wipe the internal and external surfaces of the appliance with a soft, damp cloth. Use a mild cleaning agent if required.
7. Wipe the washed surfaces with a cloth soaked in fresh water.
8. Clean the door and the appliance door seal of the appliance with a soft, damp cloth.
9. Dry washed surfaces thoroughly afterwards.
10. After cleaning, leave the door open for the appliance to dry completely.

## Cleaning and Maintenance

---

11. At least once a year wipe dust collected at the rear wall of the refrigerator and the compressor.

**ATTENTION!**

**Soiled compressor negatively affects operation of the appliance and increases power consumption.**

Never clean the compressor with water!

Use a soft, dry brush, electrostatic cloth or vacuum cleaner.

### 6.3 Maintenance

Let the appliance to be inspected by professional technician at least once a year or as required.

### 7 Possible Malfunctions

The table below contains descriptions of possible causes and solutions to malfunctions or errors during operation of the appliance. When malfunction cannot be removed, contact the technical service.

In such a case, provide article number, model name and serial number. These data may be found in the rating plate.

Error	Possible Cause	Solution
No functions available	Plug improperly inserted into a socket	Remove the plug and insert it properly in the socket
	Electric power supply safety fuse damaged	Check the fuse, connect the appliance to another socket
	No power supply	Check the electric power supply
Insufficient cooling efficiency	Compressor obstructed with dust	Clean the compressor thoroughly
	Direct sunlight or heat sources in immediate vicinity	Move the appliance away from heat sources
	Poor air circulation around the appliance	Keep sufficient clearance from walls or other objects
	Door is not closed properly or it has been opened for too long	Close the door tightly; limit the door opening time to minimum
	Damaged or deformed door seal	Contact the service company

<b>Error</b>	<b>Possible Cause</b>	<b>Solution</b>
Insufficient cooling efficiency	Too little clearance between objects inside the appliance or too many objects in the appliance	Provide for sufficient clearance between objects inside the appliance; remove the excess of objects
	Incorrectly set temperature controller	Set the temperature control correctly
Noise level of the appliance rises	Appliance is not placed on an even surface	Place the appliance on an even surface
	Appliance touches walls or other objects	Keep sufficient clearance from walls or other objects
	Objects in the appliance in contact with each other	Provide for sufficient clearance between objects
Water is collected in the condensed water drain tray, but does not discharge correctly	Clogged discharge opening of the condensed water drain tray	Clean the discharge opening of the condensed water drain tray with the cleaning tool

**The following phenomena are not malfunctions:**

Various sounds that are generated by the cooler during operation are a normal phenomenon and do not indicate any malfunctions:

- splashing, bubbling and hums are generated by the coolant that circulates the system.
- short, louder whirring/hooting or clicking sounds may be heard when the compressor of the appliance starts.

## 8 Disposal

### Electrical Appliance

	<p>Electric appliances are marked with this symbol. Electrical appliances must be disposed of and recycled in a correct and environmentally friendly manner. You must not dispose of electric appliances with household waste. Disconnect the appliance from the power supply and remove power cord from the appliance.</p>
---	---

Electrical appliances should be returned to designated collection points.

### Coolant

The propellant used in the appliance is flammable. It should be utilised pursuant to national regulations in force.