

P(Kw)	9
I(A)	13.7
U(V)	380-415V 3N~
f(Hz)	50-60
Cable	5G1.5mm <sup>2</sup>

MA	1	2	3	4	5	⏏
	L1	L2	L3	N		
	380-415V 3N~					

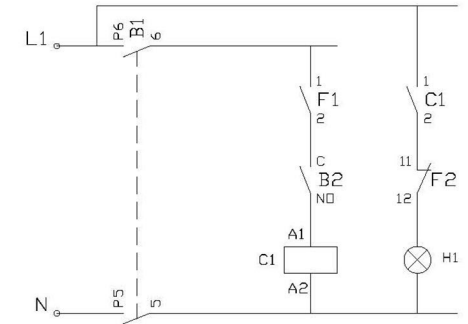
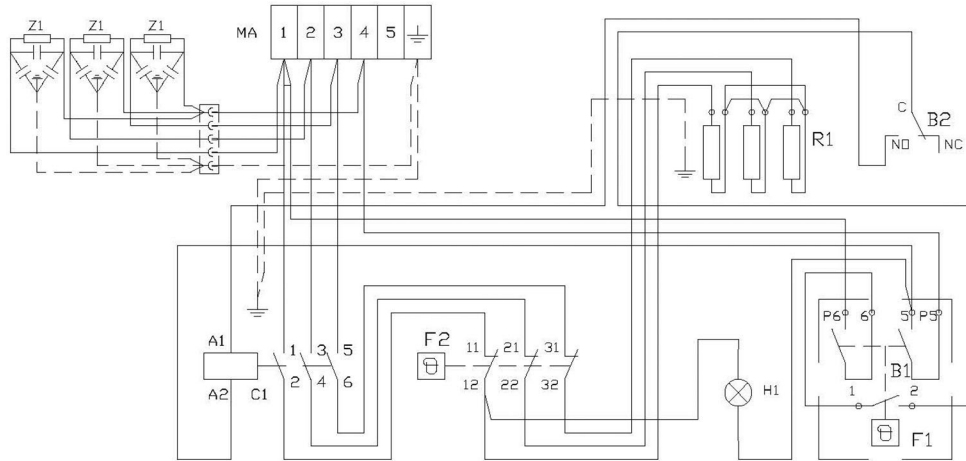

B1 CUT-OFF SWITCH EIN-AUS SCHALTER  
 B2 MICROSWITCH MICROSCHALTER  
 C1 CONTACTOR KONTAKTSCHALTER  
 F1 THERMOSTAT THERMOSTAT

F2 SAFETY THERMOSTAT TEMPERATURBEGRENZER  
 H1 ORANGE PILOTLIGHT ORANGE LAMPE  
 MA TERMINAL BLOCK ANSCHLUSSKLEMME  
 R1 HEATING ELEMENT HEIZKÖRPER  
 Z1 SUPPRESSION FILTER FUNKENTSTÖRFILTER