

* selector open 180 sec.

* selector close 90 sec.

① only for 2 speed

② only for 1 speed

	C	=	CONDENSATORE	CONDENSER/CAPACITOR	CONDENSATEUR	KONDENSATOR
	PL	=	POMPA LAVAGGIO	WASH PUMP	POMPE LAVAGE	WASCHPUMPE
	DDE	=	DOSATORE DETERSIVO ELETTRICO	ELECTRIC DETERGENT PUMP	DOSEUR ELETRIQUE DETERGENT	DOSIERGERÄT
	PS	=	POMPA SCARICO	DRAIN PUMP	POMPE DE VIDANGE	LAUGENPUMPE
	PAP	=	POMPA AUMENTO PRESSIONE	BOOSTER PUMP	SURPRESSEUR	DRUCKERHOHUNGSPUMPE (ALS ZUBEHÖR)
	ELC	=	ELETTROVALVOLA RISCIAQUO CALDO	RINSE HOT WATER SOLENOID VALVE	ELECTROSOUPAPE RINÇAGE CHAUD	WARMWASSER-MAGNETVENTIL
	ELF	=	ELETTROVALVOLA RISCIAQUO FREDDO	RINSE COLD WATER SOLENOID VALVE	ELECTROSOUPAPE RINÇAGE FROID	KALTWASSER-MAGNETVENTIL
	ELR	=	ELETTROVALVOLA RIGENERAZIONE	REGENERATION SOLENOID VALVE	ELECTROSOUPAPE REGENERATION	REGENERIERUNGSMAGNETVENTIL
	ELCR	=	ELETTROVALVOLA CARICO	LOAD SOLENOID VALVE	ELECTROSOUPAPE CHARGEMENT	ZUFLUSS-MAGNETVENTIL
	ELSC	=	ELETTROVALVOLA SCARICO	DRAIN SOLENOID VALVE	ELECTROSOUPAPE VIDANGE	ENTLEERUNGSMAGNETVENTIL
	ST	=	SPIA TEMPERATURA	TEMPERATURE LIGHT	VOYANT TEMPERATURE	TEMPERATURSLEUCHTE
	SC	=	SPIA CICLO	CYCLE LIGHT	VOYANT CYCLE	BETRIEBSLEUCHTE
	SPR	=	SPIA RIGENERAZIONE	REGENERATION CYCLE LIGHT	VOYANT REGENERATION	REGENERIERUNGSLEUCHTE
	SR	=	SPIA RETE	MAIN SWITCH LIGHT	VOYANT RESEAU ELECTRIQUE	NETZEWKLSLEUCHTE
	SA	=	SPIA ALLARME	ALARM WARNING LIGHT	VOYANT ALARME	ALARM-ANZEIGER
	SV	=	SPIA VASCA	TANK LEVEL LIGHT	VOYANT NIVEAU CUVE	TANKWASSERNIVEAULAMPE
	RB	=	RESISTENZA BOILER	BOILER HEATING ELEMENT	RESISTANCE SURCHAUFFEUR	BOILERHEIZUNG
	RV	=	RESISTENZA VASCA	TANK HEATING ELEMENT	RESISTANCE CUVE	TANKHEIZUNG
	IG	=	INTERRUTTORE GENERALE	MAIN SWITCH	INTERRUPTEUR GENERAL	HAUPTSCHALTER
	IGD	=	INTERRUTTORE GENERALE STAND BY	STAND BY MAIN SWITCH	INTERUPTEUR GENERAL STAND BY	HAUPTSCHALTER STAND BY
	MPC	=	MICRO PORTA Contatto	DOOR SAFETY SWITCH	MICRO SECURITE PORTE	MIKROTÜRKONTAKT
	MPM	=	MICRO PORTA Magnetico	MAGNETIC DOOR SAFETY SWITCH	MICRO SECURITE PORTE MAGNETIQUE	MAGNETISCHE SICHERHEITSMIKROTÜR
	PPS	=	PULSANTE POMPA SCARICO	DRAIN PUMP SWITCH	BOUTON POMPE DE VIDANGE	ENTLEERUNGSPUMPE-SCHALTER
	PR	=	PRESSOSTATO	PRESSURE SWITCH	PRESSOSTAT	DRUCKWÄCHTER
	PC	=	PULSANTE CICLO	CYCLE SWITCH	BOUTON DEMARREUR	TASTSCHALTER F. PROGRAMMANFLAU
	PCR	=	PULSANTE CICLO RIGENERAZIONE	REGENERATION CYCLE SWITCH	VOYANT REGENERATION	REGENERIERUNGSBETRIEBSLEUCHTE
	PRF	=	PULSANTE RISCIAQUO FREDDO	RINSE COLD WATER SWITCH	BOUTON DE RINÇAGE FROID	KALTESPUHLUNG SCHALTER
	PCI	=	PULSANTE CICLO INFINITO	UNLIMITED CYCLE PUSH BUTTON	BOUTON CYCLE SANS ARRÊT	PAUSELOS ZYKLUSKNOPF
	PPG	=	PULSANTE PROGRAMMAZIONE	PROGRAMMATION SWITCH	BOUTON PROGRAMMATION	PROGRAMMSCHALTER
	DEV/A/M	=	DEV. AUTOMATICO/MANUALE	AUTOMATIC/MANUAL SWITCH	SELECTEUR AUTOMATIQUE/MANUAL	AUTOMATISCHER/MANUAL WAHLER
	DEV/C/F	=	DEV. RISCIAQUO CALDO/FREDDO	HOT/COLD RINSING SWITCH	COMM. DE RINÇAGE CHAUD/FROID	UMSCHALTER F. KALT WARMWASSER
	TSP	=	TERMOSTATO SICUREZZA POMPA	PUMP SAFETY THERMOSTAT	THERMOSTAT SECURITE POMPE	SICHERUNGSTHERMOSTAT DER PUMPE
	TV	=	TERMOSTATO VASCA	TANK THERMOSTAT	THERMOSTAT CUVE	TANKTHERMOSTAT
	TB	=	TERMOSTATO BOILER	BOILER THERMOSTAT	THERMOSTAT SURCHAUFFEUR	BOIERTHERMOSTAT
	TS	=	TERMOSTATO SICUREZZA	SAFETY THERMOSTAT	THERMOSTAT DE SECURITE	SICHERHEITSTHERMOSTAT
	MTz	=	TIMER CICLO	CYCLE TIMER	PROGRAMMATEUR DU CYCLE	ZYKLUSTIMER
	MTzR	=	MOTORE TIMER RIGENERAZIONE	REGENERATION CYCLE MOTOR	MOTEUR DU RIGENERATION	SINCHRONMOT.F. REGENERIERUNGS TIMER
	MTz(L)	=	MOTORE LENTO (MTz)	SLOW (MTz)	(MTz) LENT	LANGSAMER MOTOR
	MTz(V)	=	MOTORE VELOCE (MTz)	FAST (MTz)	(MTz) RAPIDE	SCHNELLER MOTOR
	MT5	=	CONTATTORE TIMER BOBINA	CONTACTOR TIMER	CONTACTEUR DU PROGRAMMATEUR	NT5 SCHALTERKONTAKT
	KR	=	TELERUTTORE RESISTENZA	HEATING ELEMENT CONTACTOR	TELERUPTEUR RESISTANCE	HEIZUNGFERNSCHALTER-SCHÜTZ
	KPAP	=	TELERUTTORE PAP	BOOSTER PUMP CONTACTOR	TELERUPTEUR SURPRESSEUR	FERNSCHALTER-SCHÜTZ
	KP	=	TELERUTTORE POMPA	PUMP CONTACTOR	TELERUPTEUR POMPE	PUMPEFERNASCHALTER-SCHÜTZ
	KB KBIN	=	TELERUTTORE BOILER	BOILER CONTACTOR	TELERUPTEUR SURCHAUFFEUR	BOILERFERNASCHALTER-SCHÜTZ
	KV	=	TELERUTTORE VASCA	TANK CONTACTOR	TELERUPTEUR CUVE	TANKFERNASCHALTER-SCHÜTZ
	RLn°	=	RELE'	RELAY	RELAIS	RELAIS
	TPS	=	TIMER POMPA SCARICO	DRAIN PUMP TIMER	PROGRAMMATEUR POMPE DE VIDANGE	LAUGENPUMPE TIMER
	RM	=	RELE' TERMICO	THERMIC RELAY	RELAIS TERMIQUE	THERMISCH RELAIS
	BL	=	BLOCCO PORTA	DOOR LOCK	SERRAGE PORTE	TÜRRSPERRE

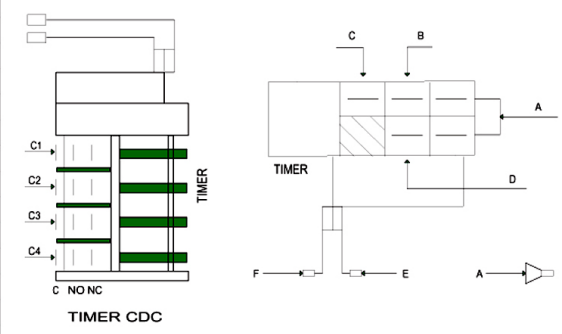
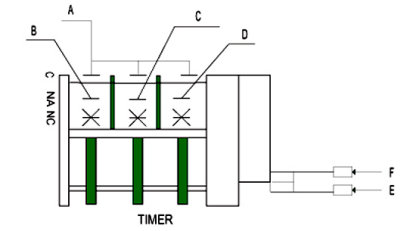
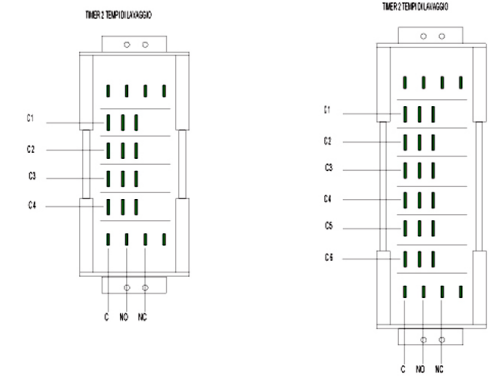

**Gläserpülmaschine
mit Wasserenthärter und Laugenpumpe**
Deltamat TF401 HP
Artikel-Nr.: 110.607

Legende
10.11.2008

	C	=	CONDENSATORE	CONDENSER	CONDENSEUR	KONDENSATEUR
	PL	=	POMPA LAVAGGIO	WASH PUMP	POMPE LAVAGE	WASCHPUMPE
	DDE	=	DOSATORE DETERGENTE ELETTRICO	ELECTRIC DETERGENT PUMP	DOSEUR ELETRIQUE DETERGENT	DOSIERGERÄT
	PS	=	POMPA SCARICO	DRAIN PUMP	POMPE DE VIDANGE	LAUGENPUMPE
	PAP	=	POMPA AUMENTO PRESSIONE	BOOSTER PUMP	SURPRESSEUR	DRUCKERHOHUNGSPUMPE (ALS ZUBEHÖR)
	ELC	=	ELETTROVALVOLA RISCIAQUO CALDO	RINSE HOT WATER SOLENOID VALVE	ELECTROSOUAPE RINÇAGE CHAUD	WARMWASSER-MAGNETVENTIL
	ELF	=	ELETTROVALVOLA RISCIAQUO FREDDO	RINSE COLD WATER SOLENOID VALVE	ELECTROSOUAPE RINÇAGE FROID	KALTWASSER-MAGNETVENTIL
	ELR	=	ELETTROVALVOLA RIGENERAZIONE	REGENERATION SOLENOID VALVE	ELECTROSOUAPE REGENERATION	REGENERIERUNGSMAGNETVENTIL
	ELCR	=	ELETTROVALVOLA CARICO	LOAD SOLENOID VALVE	ELECTROSOUAPE CHARGEMENT	ZUFLUSS-MAGNETVENTIL
	ELSC	=	ELETTROVALVOLA SCARICO	DRAIN SOLENOID VALVE	ELECTROSOUAPE VIDANGE	ENTLEERUNGSMAGNETVENTIL
	ST	=	SPIA TEMPERATURA	TEMPERATURE LIGHT	VOYANT TEMPERATURE	TEMPERATURSLEUCHE
	SC	=	SPIA CICLO	CYCLE LIGHT	VOYANT CYCLE	BETRIEBSLEUCHE
	SPR	=	SPIA RIGENERAZIONE	REGENERATION CYCLE LIGHT	VOYANT REGENERATION	REGENERIERUNGSLEUCHE
	SR	=	SPIA RETE	MAIN SWITCH LIGHT	VOYANT RESEAU ELECTRIQUE	NETZWERKSLEUCHE
	SA	=	SPIA ALLARME	ALARM WARNING LIGHT	VOYANT ALARME	ALARMA-ANZEIGER
	SV	=	SPIA VASCA	TANK LEVEL LIGHT	VOYANT NIVEAU CUVE	TANKWASSERNIVEAULAMPE
	RB	=	RESISTENZA BOILER	BOILER HEATING ELEMENT	RESISTANCE SURCHAUFFEUR	BOILERHEIZUNG
	RV	=	RESISTENZA VASCA	TANK HEATING ELEMENT	RESISTANCE CUVE	TANKHEIZUNG
	IG	=	INTERRUTTORE GENERALE	MAIN SWITCH	INTERRUPTEUR GENERAL	HAUPTSCHALTER
	IGD	=	INTERRUTTORE GENERALE STAND BY	STAND BY MAIN SWITCH	INTERUPTEUR GENERAL STAND BY	HAUPTSCHALTER STAND BY
	MPC	=	MICRO PORTA Contatto	DOOR SECURITY SWITCH	MICRO SECURITE PORTE	MIKROTÜRKONTAKT
	MPM	=	MICRO PORTA Magnetico	MAGNETIC DOOR SECURITY SWITCH	MICRO SECURITE PORTE MAGNETIQUE	MAGNETISCHE SICHERHEITSMIKROTÜR
	PPS	=	PULSANTE POMPA SCARICO	DRAIN PUMP SWITCH	BOUTON POMPE DE VIDANGE	ENTLEERUNGSPUMPE-SCHALTER
	PR	=	PRESSOSTATO	PRESSURE SWITCH	PRESSOSTAT	DRUCKWÄCHTER
	PC	=	PULSANTE CICLO	CYCLE SWITCH	BOUTON DEMARREUR	TASTSCHALTER F. PROGRAMMANFLAU
	PCR	=	PULSANTE CICLO RIGENERAZIONE	REGENERATION CYCLE SWITCH	VOYANT REGENERATION	REGENERIERUNGSBETRIEBSLEUCHE
	PRF	=	PULSANTE RISCIAQUO FREDDO	RINSE COLD WATER SWITCH	BOUTON DE RINÇAGE FROID	KALTESPUHLUNG SCHALTER
	PCI	=	PULSANTE CICLO INFINITO	UNLIMITED CYCLE PUSH BUTTON	BOUTON CYCLE SANS ARRET	PAUSENLOS ZYKLUSKNOPF
	PPG	=	PULSANTE PROGRAMMAZIONE	PROGRAMMATION SWITCH	BOUTON PROGRAMMATION	PROGRAMMSCHALTER
	DEVAM	=	DEV. AUTOMATICO/MANUALE	AUTOMATIC/MANUAL SWITCH	SELECTEUR AUTOMATIQUE/MANUAL	AUTOMATISCHER/MANUAL WAHLER
	DEVCF	=	DEV. RISCIAQUO CALDO/FREDDO	HOT/COLD RINSING SWITCH	COMM. DE RINÇAGE CHAUD/FROID	UMSCHALTER F. KALT WARMWASSER
	TSP	=	TERMOSTATO SICUREZZA POMPA	PUMP SECURITY THERMOSTAT	THERMOSTAT SECURITE POMPE	SICHERUNGSTERMOSTAT DER PUMPE
	TV	=	TERMOSTATO VASCA	TANK THERMOSTAT	THERMOSTAT CUVE	TANKTHERMOSTAT
	TB	=	TERMOSTATO BOILER	BOILER THERMOSTAT	THERMOSTAT SURCHAUFFEUR	BOIERTHERMOSTAT
	TS	=	TERMOSTATO SICUREZZA	SECURITY THERMOSTAT	THERMOSTAT DE SECURITE	SICHERHEITSTERMOSTAT
	PR / PB	=	PRESSOSTATO	PRESSURE ATMOSPHERIC BOILER	PRESSOSTAT ATMOSPHERIQUE	DRUCKWÄCHTER BOILER ATMOSPHÄRISCHE
	MT5	=	CONTATTORE TIMER BOBINA	CONTACTOR TIMER	CONTACTEUR DU PROGRAMMATEUR	NT5 SCHALTERKONTAKT
	KLR	=	TELERUTTORE RESISTENZA	HEATING ELEMENT CONTACTOR	TELERUPTEUR RESISTANCE	HEIZUNGFERNSCHALTER-SCHÜTZ
	KPAP	=	TELERUTTORE PAP	BOOSTER PUMP CONTACTOR	TELERUPTEUR SURPRESSEUR	FERNSCHALTER-SCHÜTZ
	KP	=	TELERUTTORE POMPA	PUMP CONTACTOR	TELERUPTEUR POMPE	PUMPEFERNASCHALTER-SCHÜTZ
	KB KB/N	=	TELERUTTORE BOILER	BOILER CONTACTOR	TELERUPTEUR SURCHAUFFEUR	BOILERFERNASCHALTER-SCHÜTZ
	KV	=	TELERUTTORE VASCA	TANK CONTACTOR	TELERUPTEUR CUVE	TANKFERNASCHALTER-SCHÜTZ
	RLn'	=	RELE'	RELAY	RELAIS	RELAIS
	TPS	=	TIMER POMPA SCARICO	DRAIN PUMP TIMER	PROGRAMMATEUR POMPE DE VIDAGE	LAUGENPUMPE TIMER
	RM	=	RELE' TERMICO	THERMIC RELAY	RELAIS TERMIQUE	THERMISCH RELAIS
	BL	=	BLOCCO PORTA	DOOR LOCK	SERRAGE PORTE	TÜRRSPERRE
	ELBT	=	ELETTROVALVOLA BREAK TANK	BREAK TANK SOLENOID VALVE	ELECTROSOUAPE DU SYSTEME ANTI RETOUR	BREAK TANK SYSTEM MAGNETVENTIL
	PRBT	=	PRESSOSTATO BREAK TANK	BREAK TANK PRESSURE SWITCH	PRESSOSTAT DU SYSTEME ANTI RETOUR	BREAK TANK SYSTEM DRUCKWÄCHTER
	PLIFT	=	POMPA LIFT	LIFT PUMP	POMPE SYSTEME RELEVAGE CAPOT	LIFT PUMPE
	ELLF	=	ELETTROVALVOLA LIFT	LIFT SOLENOID VALVE	ELECTROSOUAPE SYSTEME RELEVAGE CAPOT	LIFT SYSTEM MAGNETVENTIL
	PRLF	=	PRESSOSTATO LIFT	LIFT PRESSURE SWITCH	PRESSOSTAT SYSTEME RELEVAGE CAPOT	LIFT SYSTEM DRUCKWÄCHTER

MARRONE	BROWN	MARON	BRAUN
CELESTE	BLUE	BLEU-CLAIR	HELL BLAU
NERO	BLACK	NOIR	SCHARZ
ROSSO	RED	ROUGE	ROT
VERDE	GREEN	VERT	GRÜN
BIANCO	WHITE	BLANC	WEISS
GRIGIO	GREY	GRIS	GRAU
ARANCIO	ORANGE	ORANGE	ORANGE
VIOLA	VIOLET	VIOLET	VIOLET
BLU	BLEU	BLEU	BLAU



Gläserpülmaschine
mit Wasserenthärter und Laugenpumpe
Deltamat TF401 HP
Artikel-Nr.: 110.607

Legende
10.11.2008