

Durchschub-Spülmaschine DS 2001
 Artikel-Nr.: 109249

Schaltplan
 06.04.2016

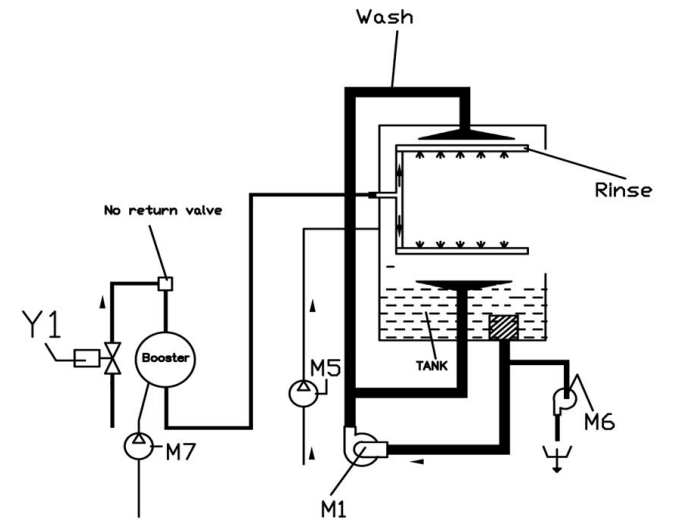

S6	PULSANTE DI LINEA MAIN SWITCH	INTERRUPTEUR DE LIGNE NETZSCHALTER		
B5	MICROINTERRUTTORE MAGNETICO MAGNETIC SAFETY MICROSWITCH	MICROINTERRUPTEUR MAGNETIQUE MAGNETISCHER SICHERHEITSSCHALTER		
S3 S2	INTERRUTTORE DI CICLO CYCLE SWITCH	INTERRUPTEUR DE DEMARRAGE WASCHVORGANGSSCHALTER		
S4	SELETORE CICLO CYCLE COMMUTATOR	SELECTEUR CYCLE WAEHLSCHALTER FUER WASCHVORGANGSDAUER		
F1	TERMOSTATO SICUREZZA BOILER SAFETY BOOSTER HEATER THERMOSTAT	THERMOSTAT DE SICURITE DU BOYLER SICHERHEITZUNG		
F3	TERMOSTATO SICUREZZA VASCA SAFETY TANK HEATER THERMOSTAT	THERMOSTAT DE SICURITE CUVE SICHERHEITS- TANKTHERMOSTAT		
R3	RESISTENZA VASCA LAVAGGIO WASH TANK HEATING ELEMENT	RESISTANCE CUVE DE LAVAGE WASHTANKHEIZUNG		
R1	RESISTENZA BOILER BOOSTER HEATER HEATING ELEMENT	RESISTANCE BOYLER BOILERHEIZUNG		
M7	ELETTRODOSATORE TENSOATTIVO EL. RINSE/ID INJECTOR	DOSEUR EL. PRODUIT RINCAGE NACHSPUELMITTELDOSIERGERAET		
M6	ELETTROPOMPA DI SCARICO DRAIN PUMP	MOTEUR POMPE VIDANGE MOTOR LAUGENPUMPE		
M2	ELETTROPOMPA AUMENTO PRESSIONE RINSE BOOSTER PUMP	ELECTROPOMPE AUGMENT PRESSION DRUCKSTEIGERUNGSPUMPE		
M5	ELETTRODOSATORE DETERSIVO EL. DETERGENT INJECTOR	DOSEUR EL. DETERGENT SPUEL MITTELDOSIERGERAET		
M1	ELETTROPOMPA LAVAGGIO WASH ELECTRIC PUMP	ELECTROPOMPE LAVAGE ELEKTRISCHE UMAELZPUMPE		
KR1	TELERUTTORE SICUREZZA RESISTENZA BOILER SAFETY BOOSTER HEATER CONTACTOR	CONTACTEUR RESISTANCE BOYLER LUFTSCHUETZ F. BOILERHEITZUNG		
KR2	TELERUTTORE RESISTENZA VASCA TANK HEATER CONTACTOR			
KR3	TELERUTTORE RESISTENZA BOILER BOOSTER HEATER CONTACTOR	CONTACTEUR RESISTANCE BOYLER LUFTSCHUETZ F. BOILERHEITZUNG		
KM1	TELERUTTORE ELETTROPOMPA LAVAGGIO WASCH PUMP CONTACTEUR	CONTACTEUR ELECTROPOMPE LAVAGE SCHUETZ F. UMWAEHPUMPE		
Y1	ELETTROVALVOLA RISCIAQUO RINSE SOLENOID VALVE	ELECTROVANNE DE RINCAGE MAGNETVENT FUER NACHSPUELUNG		
F1	FUSIBILE FEUSES			
E2	SONDA CONTROLLO VASCA PROBE TANK HEATER	THERMOSTAT RESISTANCE CUVE TANKHEIZUNG/THERMOSTAT		
E1	SONDA CONTROLLO BOILER BOOSTER HEATER THERMOSTAT	THERMOSTAT RESISTANCE BOYLER BOILERHEIZUNG		
C1	CONDENSATORE CAPACITOUR			
B16	PRESSOSTATO LIVELLO SICUREZZA SAFETY TANK LEVEL PRESSURE SWITCH			
B10	PRESSOSTATO LIVELLO VASCA TANK PRESSURE SWITCH	PRESSOSTAT NIVEAU AIRGAP TANKDRUCKSCHALTER-NIVEAUREGLER		
M/R/S	SCHEDA CONTROLLO ELECTRONIC CONTROL UNIT	FICHE DE CONTROLEELECTRONIQUE ELEKTRONISCHE BEDIENUNGSKARTE		
SIMB.	DESCRIZIONE DESCRIPTION	DESCRIPTION BESCHREIBUNG		

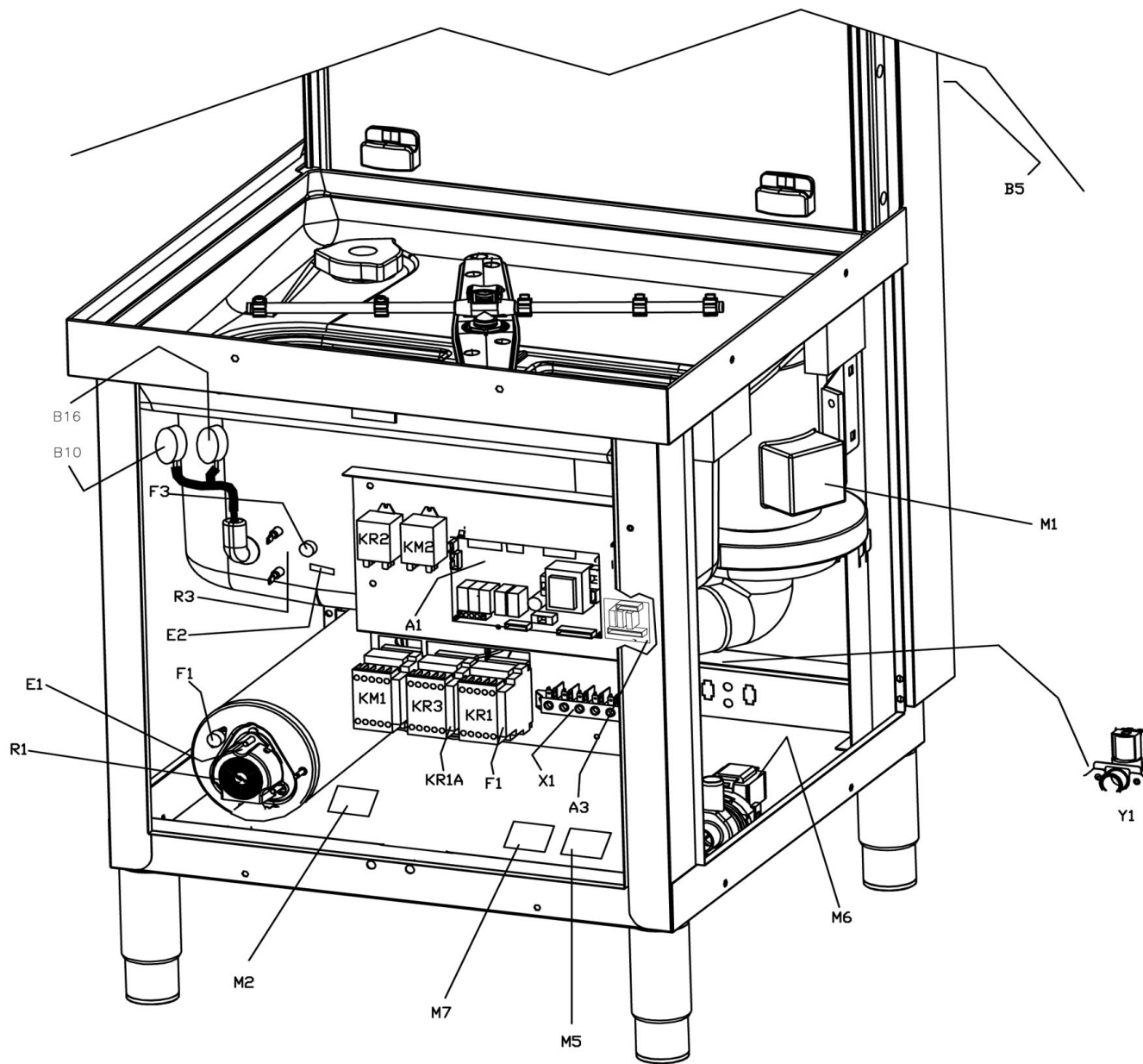