

# TS 301



**A300073**



<b>DEUTSCH</b>	-----	<b>Seite 1 bis 4</b>
<b>ENGLISH</b>	-----	<b>from page 5 to 8</b>
<b>FRANÇAIS</b>	-----	<b>de page 9 à page 12</b>
<b>ITALIANO</b>	-----	<b>pagine da 13 a 16</b>
<b>ESPAÑOL</b>	-----	<b>de la página 17 a la 20</b>
<b>PORTUGUÊS</b>	-----	<b>as páginas des de 21 até 24</b>
<b>NEDERLANDS</b>	-----	<b>blz. 25 t/m 28</b>
<b>DANSK</b>	-----	<b>side fra 29 til og med 32</b>
<b>РУССКИЙ</b>	-----	<b>страница 33 до 36</b>
<b>TÜRKÇE</b>	-----	<b>sayfalar: 37-40</b>
<b>POLSKI</b>	-----	<b>strony od 41 do 44</b>
<b>ČESKY</b>	-----	<b>stránka 45 až 48</b>
<b>HRVATSKI</b>	-----	<b>stranica 49 do 52</b>
<b>MAGYAR</b>	-----	<b>53 – 56. oldal</b>
<b>ΕΛΛΗΝΙΚΑ</b>	-----	<b>σελίδες από 57 ως 60</b>



## Technische Angaben











---

- Bezeichnung: • **Servier-/Transportwagen TS 301 mit 3 Ebenen**
- Art.-Nr.: • **A300073**
- Material: • Chromnickelstahl
- Ausführung: • Rahmen: aus Rundrohr Ø 25,8 mm;  
Borde: 3, Maße, je: B 827 x T 510 mm  
4 gummbereifte Lenkrollen, Ø 100 mm  
je 1 Radpuffer, 2 Lenkrollen mit Feststellern  
Bausatz, einfache Montage
- Abmessungen: • B 920 x T 600 x H 945 mm
- Tragfähigkeit max.: • 90 kg, 30 kg pro Bord
- Abstand zwischen den Borden: • 265 mm
- Gewicht: • 13,4 kg
- 

Technische Änderungen vorbehalten!

- Packen Sie die einzelnen Teile aus und entsorgen Sie umweltgerecht das Verpackungsmaterial.
- Kontrollieren Sie die Lieferung auf Vollständigkeit anhand folgender Liste.

## Lieferumfang / Teilebezeichnung

Bauteile	Menge	Bezeichnung
	3	Borde
	2	Bügel
	2	Lenkrollen ohne Feststeller
	2	Lenkrollen mit Feststellern
	4	Radpuffer
	12	Befestigungswinkel
	12	Inbusschrauben
	12	Kontermutter
	1	Inbusschlüssel
	1	Maulschlüssel

## Montage

1. Beginnen Sie den Aufbau des Servier-/Transportwagens mit der Befestigung der Borde an den Bügeln.  
Legen Sie die Befestigungswinkel von innen in die Ecken der Borde. Schrauben Sie diese mit Hilfe des Inbuss- und Maulschlüssels mit den beiliegenden Inbusschrauben und Muttern an den Bügeln fest.

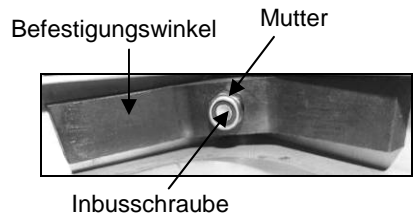

2. Legen Sie den Servier-/Transportwagen auf die Seite und befestigen Sie die Radpuffer an den Bügeln. Schrauben Sie dann die Lenkrollen in die Bügel.

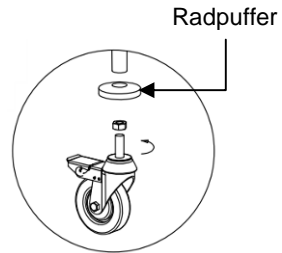

3. Stellen Sie den Servier-/Transportwagen vorsichtig auf den Boden und stellen Sie sicher, dass die vier Lenkrollen den Boden berühren. Sie können die Nivellierung des Servier-/Transportwagens mit Hilfe der Lenkrollen vornehmen, indem Sie diese ein- oder ausdrehen. Fixieren Sie diese nun mit Hilfe der Kontermuttern.



### HINWEIS!

**Entfernen Sie die Schutzfolie nach der Montage!**

4. Wenn Sie den Servier-/Transportwagen am gewünschten Platz aufgestellt haben, sichern Sie die Feststeller an den Lenkrollen, damit der Servier-/Transportwagen nicht versehentlich verschoben oder umgekippt werden kann.

## Reinigungshinweise

- Reinigen Sie den Servier-/Transportwagen regelmäßig mit einem feuchten, weichen Tuch und mildem Reiniger.
- Benutzen Sie niemals grobe Reiniger, welche die Oberfläche des Servier-/Transportwagens zerkratzen können.
- Trocknen Sie den Servier-/Transportwagen mit einem weichen Tuch ab.

Bartscher GmbH  
Franz-Kleine-Str. 28  
33154 Salzkotten  
Germany

Tel.: +49 (0) 5258 971-0    **Service-Hotline: 0180 5 971 197**  
Fax: +49 (0) 5258 971-120 (14ct/Min. aus dem deutschen Festnetz)



## Technical data

---











Name:	<ul style="list-style-type: none"><li>• <b>Serving-/transport trolley TS 301 with 3 shelves</b></li></ul>
Code-No.:	<ul style="list-style-type: none"><li>• <b>A300073</b></li></ul>
Material:	<ul style="list-style-type: none"><li>• Nickel-chrome steel</li></ul>
Design:	<ul style="list-style-type: none"><li>• Frame made of round tubes Ø 25,8 mm; Shelves: 3, dimension: W 827 x D 510 mm 4 swivelling rubber castors, Ø 100 mm 1 buffer, 2 swivelling castors with stoppers Easy assembly</li></ul>
Dimensions:	<ul style="list-style-type: none"><li>• W 920 x D 600 x H 945 mm</li></ul>
Maximum carrying capacity:	<ul style="list-style-type: none"><li>• 90 kg, 30 kg per shelf</li></ul>
Distance between shelves:	<ul style="list-style-type: none"><li>• 265 mm</li></ul>
Weight:	<ul style="list-style-type: none"><li>• 13.4 kg</li></ul>

---

We reserve the right to make technical changes!

- Unpack the individual elements and remove the packaging material.
- Check completeness of delivery according to the list below.

## Scope of delivery / Part name

Element	Number	Name
	3	Shelf
	2	Frame
	2	Castors without stoppers
	2	Castors with stoppers
	4	Buffers for castors
	12	Mounting angle
	12	Hexagon socket screws
	12	Lock nut
	1	Allen wrench
	1	Wrench

## Assembly

1. Start the assembly of the serving / transport trolley from fixing the shelves to the frame. Insert the mounting angles inside the corners of the frame. Screw them tight with the use of an Allan wrench and the wrench and the included hexagon socket screws and the nut.

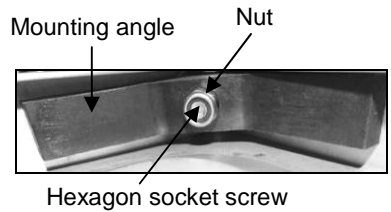

2. Lay the serving / transport trolley on its side and attach castor buffers to the frame. Finally, next, screw 4 swivel castors into the frame.

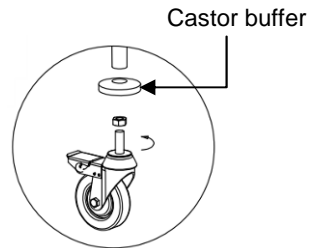

3. Carefully place the serving / transport trolley on the floor and make sure that all swivel castors touch the surface. The serving / transport trolley may be aligned by adjusting swivel castors. Secure their position with lock nuts.



### NOTE!

**Remove the protective foil after the assembly!**

4. When the serving / transport trolley is in the desired location, block the swivel castors with brakes, to prevent it from being accidentally moved or tipped.

## Cleaning instructions

- The serving / transport trolley should be regularly cleaned with a moist cloth and mild cleaning agents.
- **Never** use harsh cleaning agents that may damage the surface of the serving / transport trolley.
- Dry the serving / transport trolley with a soft cloth.

## Données techniques











---

- Nom : • **Chariot service-/transport TS 301 à 3 niveaux**
- Code-No. : • **A300073**
- Matériau : • Acier inoxydable
- Réalisation : • Cadre : tubes arrondis Ø 25,8 mm;  
Plateau : 3, dimensions de chaque plateau : largeur 827 x profondeur 510 mm  
4 roulettes pivotantes à bandage caoutchouc, Ø 100 mm chacune avec 1 tampon, 2 roulettes pivotantes avec freins  
Livré en kit, montage simple
- Dimensions : • largeur 920 x profondeur 600 x hauteur 945 mm
- Capacité de charge max. : • 90 kg, 30 kg par plateau
- Distance entre les plateaux : • 265 mm
- Poids : • 13,4 kg
- 

Sous réserve de modifications techniques !

- Déballer chaque pièce et éliminer l'emballage.
- Vérifier s'il ne manque pas de pièces selon la liste ci-dessous.

## Livraison / Noms des pièces

Élément	Quantité	Nom
	3	Plateau
	2	Cadre
	2	Roulettes pivotantes sans freins
	2	Roulettes pivotantes avec freins
	4	Tampon de roulette
	12	Cornière de fixation
	12	Vis Allen
	12	Contre-écrou
	1	Clé Allen
	1	Clé plate à molette

## Montage

1. Commencer le montage du chariot de service/transport en fixant les roulettes au cadre. Placer les cornières de fixation, de l'intérieur, dans les angles du cadre. Les visser au cadre à l'aide de la clé Allen et de la clé plate à molette fournies avec la vis Allen et l'écrou.

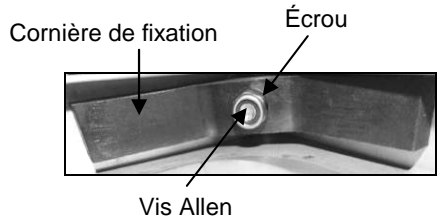

2. Placer le chariot de service/transport sur le côté et fixer au cadre les tampons de roulette. Enfin, attacher les 4 roulettes pivotantes au cadre.

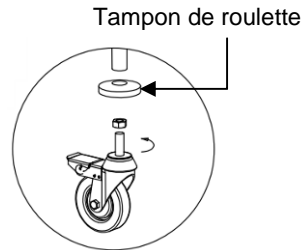

3. Placer le chariot de service/transport délicatement sur le sol et s'assurer que toutes les quatre roulettes pivotantes touchent le sol. Il est possible de niveler le chariot de service/transport à l'aide des roulettes pivotantes, en les vissant ou en les dévissant. Fixer leur position à l'aide des écrous.



### INDICATION !

**Une fois le montage terminé, retirer le film de protection !**

4. Une fois le chariot de service/transport placé à l'endroit souhaité, bloquer les roulettes pivotantes à l'aide des freins pour que le chariot de service/transport ne soit pas par hasard déplacé ni renversé.

## Conseils concernant le nettoyage

- Nettoyer régulièrement le chariot de service/transport à l'aide d'un chiffon doux et humide et d'un produit nettoyant doux.
- Dans tous les cas, il est interdit d'utiliser des produits nettoyants qui pourraient rayer la surface des éléments du chariot de service/transport.
- Essuyer et sécher le chariot de service/transport avec un chiffon doux.



## Dati tecnici

---











Nome:	<ul style="list-style-type: none"><li>• <b>Carrello da servizio-/trasporto TS 301 con 3 mensole</b></li></ul>
N. art.:	<ul style="list-style-type: none"><li>• <b>A300073</b></li></ul>
Materiale:	<ul style="list-style-type: none"><li>• Acciaio al nichel-cromo;</li></ul>
Realizzazione:	<ul style="list-style-type: none"><li>• Telaio: in tubi a sezione circolare Ø 25,8 mm; Mensola: 3, dimensioni di ogni mensola: L 827 x P 510 mm 4 ruote sterzanti in gomma, Ø 100 mm 1 paracolpi, 2 ruote sterzanti con freni Kit da assemblare, facile montaggio</li></ul>
Dimensioni:	<ul style="list-style-type: none"><li>• L 920 x P 600 x A 945 mm</li></ul>
Portata massima:	<ul style="list-style-type: none"><li>• 90 kg, 30 kg per mensola</li></ul>
Spazio tra le mensole	<ul style="list-style-type: none"><li>• 265 mm</li></ul>
Peso:	<ul style="list-style-type: none"><li>• 13,4 kg</li></ul>

---

Il fabbricante si riserva la possibilità di apportare modifiche tecniche!

- Estrarre i vari elementi dall'imballaggio e smaltire il materiale.
- Verificare la completezza della consegna in base alla lista a seguire.

## Ambito della consegna/Nomi dei pezzi

Elemento	Quantità	Nome
	3	Mensola
	2	Telaio
	2	Ruote sterzanti senza freni
	2	Ruote sterzanti con freni
	4	Paracolpi della ruota
	12	Profilo ancolare di fissaggio
	12	Viti a brugola
	12	Controdado
	1	Chiave a brugola
	1	Chiave piatta

## Montaggio

1. Cominciare il montaggio del carrello da servizio/trasporto dal fissaggio della mensola al telaio. Inserire i profili angolari di fissaggio dall'interno, presso gli angoli del telaio. Stringerli al telaio con la chiave a brugola e la chiave piatta, utilizzando le viti a brugola e i dadi forniti in dotazione.

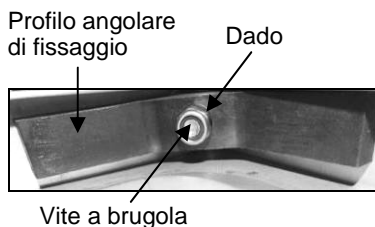

2. Posizionare il carrello da servizi/trasporto su un lato e fissare al telaio i paracolpi delle ruote. Alla fine, avvitare al telaio le 4 ruote sterzanti.

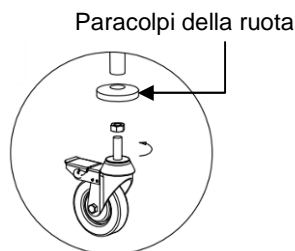

3. Posizionare il carrello da servizio/trasporto sul pavimento e accertarsi che tutte e quattro le ruote sterzanti tocchino il piano di appoggio. Il carrello da servizio/trasporto può essere livellato con le ruote sterzanti, avvitandole o svitandole. Definire la loro posizione con i controdadi.



### **INDICAZIONE!**

**Dopo il montaggio, rimuovere la pellicola protettiva!**

4. Dopo il posizionamento del carrello da servizio/trasporto nel luogo richiesto, bloccare le ruote sterzanti con i freni, in modo tale che il carrello non venga spostato o rovesciato inavvertitamente.

## Indicazioni per la pulizia

- Il carrello da servizio/trasporto andrà pulito regolarmente con un panno morbido e umido, servendosi di un detergente delicato.
- Non usare mai detergenti tali da danneggiare la superficie degli elementi del carrello.
- Asciugare il carrello da servizio/trasporto con un panno morbido.

## Datos técnicos

---











Nombre:	<ul style="list-style-type: none"><li>• <b>Carro camarera-/de transporte TS 301 con 3 niveles</b></li></ul>
Código:	<ul style="list-style-type: none"><li>• <b>A300073</b></li></ul>
Material:	<ul style="list-style-type: none"><li>• Acero al cromo-níquel</li></ul>
Fabricación:	<ul style="list-style-type: none"><li>• Bastidor de tubos circulares de Ø 25,8 mm; Bandeja: 3, medidas de la bandeja: anch. 827 x prof. 510 mm 4 ruedas orientables con neumáticos de caucho, Ø 100 mm, con 1 amortiguador, 2 ruedas orientables con bloqueo Conjunto para montar, instalación fácil</li></ul>
Medidas:	<ul style="list-style-type: none"><li>• an. 920 x prof. 600 x al. 945 mm</li></ul>
Capacidad de carga máx.:	<ul style="list-style-type: none"><li>• 90 kg, 30 kg por bandeja</li></ul>
Separación entre bandejas:	<ul style="list-style-type: none"><li>• 265 mm</li></ul>
Peso:	<ul style="list-style-type: none"><li>• 13,4 kg</li></ul>

---

¡Sujeto a modificaciones técnicas!

- Desempaquetar los elementos individuales y deshacerse del material de embalaje.
- Comprobar la integridad de la entrega según la siguiente lista.

## Contenido de la entrega / nombres de los elementos

Elemento	Cantidad	Nombre
	3	Bandeja
	2	Bastidor
	2	Ruedas orientables sin bloqueo
	2	Ruedas orientables con bloqueo
	4	Bloqueo de la rueda
	12	Ángulo de fijación
	12	Tornillos allén
	12	Contratuerca
	1	Llave Allén
	1	Llave inglesa plana

## Instalación

1. Empezar el montaje del carro camarera / de transporte fijando la bandeja en el bastidor. Introducir los ángulos de fijación en las esquinas del bastidor desde el interior. Apretarlos bien al bastidor por medio de la llave allén y llave inglesa plana usando el tornillo allén y la tuerca adjuntos.

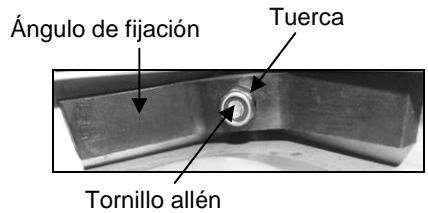

2. Colocar el carro camarera / de transporte de lado y fije los bloqueos de las ruedas al bastidor. Al final atornillar 4 ruedas giratorias al bastidor.

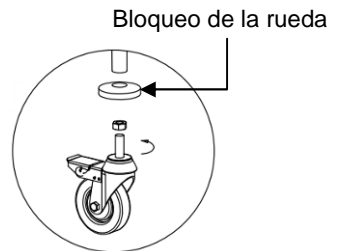

3. Con cuidado colocar el carro camarera / de transporte en el suelo y asegurarse de que todas las ruedas orientables están en contacto con el suelo. El carro camarera / de transporte se puede nivelar con las ruedas orientables, atornillándolas dentro o fuera. Fijar su posición con las contratuercas.



### ¡INDICACIÓN!

**¡Remove la película de plástico tras el montaje!**

4. Al colocar el carro camarera / de transporte en el sitio deseado, bloquear las ruedas orientables con bloqueo para que el carro no sea accidentalmente desplazado o volcado.

## Consejos para la limpieza

- Limpiar el carro camarera / de transporte con un paño blando y húmedo con adición de detergente suave.
- En ningún caso deben utilizarse productos de limpieza que puedan rayar las superficies de los elementos del carro camarera / de transporte.
- Secar el carro camarera / de transporte con un paño suave.



## Especificações

---











Nome:	<ul style="list-style-type: none"><li>• <b>Carrinho de serviço-/transporte TS 301 com 3 níveis</b></li></ul>
N.º ref.:	<ul style="list-style-type: none"><li>• <b>A300073</b></li></ul>
Material:	<ul style="list-style-type: none"><li>• Aço cromo-níquel</li></ul>
Execução:	<ul style="list-style-type: none"><li>• Estrutura: de tubos redondos Ø 25,8 mm; Bandeja: 3, dimensões de cada bandeja: L 827 x P 510 mm 4 rodas giratórias revestidas a borracha, Ø 100 mm cada com 1 amortecedor, 2 rodas giratórias com retentor Kit de montagem, montagem fácil</li></ul>
Dimensões:	<ul style="list-style-type: none"><li>• L 920 x P 600 x A. 945 mm</li></ul>
Capacidade de carga máx.:	<ul style="list-style-type: none"><li>• 90 kg, 30 kg por bandeja</li></ul>
Espaço entre bandejas:	<ul style="list-style-type: none"><li>• 265 mm</li></ul>
Peso:	<ul style="list-style-type: none"><li>• 13,4 kg</li></ul>

---

Sujeito a alterações técnicas!

- Desembalar os respetivos elementos e reutilizar o material de embalagem.
- Verificar se os elementos estão completos, com base na seguinte lista.

**Âmbito de entrega / Nome dos elementos**

<b>Elemento</b>	<b>Quantidade</b>	<b>Nome</b>
	3	Bandeja
	2	Estrutura
	2	Rodas giratórias sem retentores
	2	Rodas giratórias com retentores
	4	Amortecedor de roda
	12	Cantoneira de montagem
	12	Parafusos Allen
	12	Porca de fixação
	1	Chave allen
	1	Chave inglesa plana

## Montagem

1. Deve começar a montagem de carrinho de serviço/transporte com fixar a bandeja na estrutura. Colocar as cantoneiras de montagem desde interior em cantos da estrutura. Aperteos firmemente a estrutura usando uma chave Allen e uma chave inglesa plana que se encontra no kit com parafuso Allen e porca.

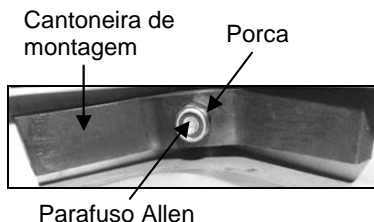

2. Colocar carrinho de serviço/transporte de lado e fixar à estrutura os amortecedores de rodas. No final, aparafusar 4 rodas giratórias à estrutura.

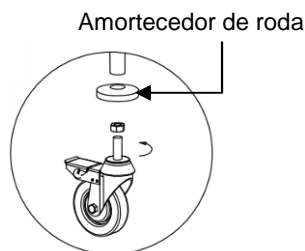

3. Cuidadosamente colocar no chão carrinho de serviço/transporte e certifique-se que todas as quatro rodas giratórias tocam o chão. O carrinho de serviço/transporte pode ser alinhado com as rodas giratórias com aparafusar ou desaparafusar-las. Determinar a sua localização utilizando as porcas de fixação.



### NOTA!

**Após a montagem remover a película protetora!**

4. Ao colocar o carrinho de serviço/transporte no local desejado, bloquear as rodas giratórias com os retentores para que o carrinho de serviço/transporte não seja acidentalmente movido ou derrubado.

## Indicações de limpeza

- Carrinho de serviço/transporte deve ser limpo regularmente com um pano úmido, macio e detergente neutro.
- Não utilize produtos de limpeza que podem arranhar os elementos de superfície do carrinho de serviço/transporte.
- Secar o carrinho de serviço/transporte com um pano macio.

## Technische gegevens











---

- Benaming: • **Serveer-/Transportwagen TS 301 met 3 niveaus**
- Nr art.: • **A300073**
- Materiaal: • CNS
- Uitvoering: • Frame: ronde buizen Ø 25,8 mm;  
Leggers: 3, afmetingen elke plank:  
br. 827 x l. 510 mm  
4 zwenkwielen met rubberen banden, Ø 100 mm  
elk 1 stootbeveiliging, 2 zwenkwielen met rem  
Bouwpakket, eenvoudige montage
- Afmetingen: • br. 920 x d. 600 x h. 945 mm
- Max. draagvermogen: • 90 kg, 30 kg per legger
- Afstand tussen de planken: • 265 mm
- Gewicht: • 13,4 kg
- 

Technische wijzigingen voorbehouden!

- Pak de afzonderlijke delen uit en verwijder het verpakkingsmateriaal op een milieuvriendelijke manier.
- Controleer aan de hand van de volgende lijst of de levering compleet is.

**Leveromvang / Benaming van de onderdelen**

Onderdelen	Aantal	Benaming
	3	Legger
	2	Frame
	2	Zwenkwielen zonder rem
	2	Zwenkwielen met rem
	4	Stootbeveiliging wiel
	12	Montagebeugel
	12	Inbusschroeven
	12	Moer
	1	Inbussleutel
	1	Steeksleutel

## Montage

1. De montage van de server-/transportwagen beginnen met het bevestigen van de leggers aan het frame. De montagebeugels bevestigen aan de binnenkant in de hoek van het frame. De geleverde inbusschroef en moer stevig aan het frame vastdraaien met behulp van de inbussleutel en de steeksleutel.

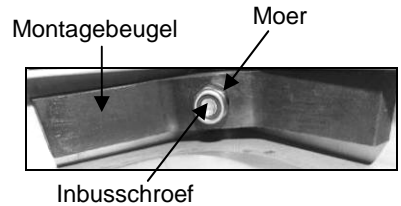

2. De server-/transportwagen op de zijkant leggen en aan het frame de stootbeveiliging voor de wielen monteren. Tot slot de 4 zwenkwielen aan het frame monteren.

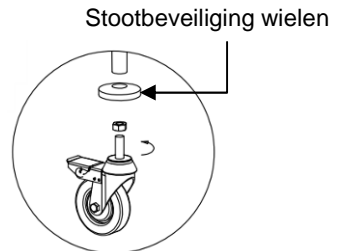

3. De server-/transportwagen voorzichtig op de grond zetten en zich ervan verzekeren dat alle vier de zwenkwielen de grond raken. De server-/transportwagen kan worden genivelleerd door de zwenkwielen in- of uit te draaien. Bepaal hun plaats met behulp van de borgmoeren.



**TIP!**

**Na de montage het beschermfolie verwijderen!**

4. Na het plaatsen van de server-/transportwagen op de gewenste plaats, de zwenkwielen blokkeren met de rem zodat de server-/transportwagen niet per ongeluk kan verschuiven of omvallen.

## **Aanwijzingen betreffende de reiniging**

- De serveer-/transportwagen dient regelmatig te worden gereinigd met een vochtig zacht doekje met een mild reinigingsmiddel.
- In geen geval reinigingsmiddelen gebruiken die het oppervlak van de elementen van de serveer-/transportwagen kunnen bekrassen.
- De serveer-/transportwagen drogen met een zachte doek.



## Tekniske data











---

- Navn: • **Serverings-/transportvogn TS 301 med 3 niveauer**
- Art. nr.: • **A300073**
- Materiale: • Krom-nikkel stål
- Udførelse: • Ramme: runde rør Ø 25,8 mm;  
Hylde: 3, hylde dimensioner:  
bredde 827 x dybde 510 mm  
4 styreruller med gummiring, Ø 100 mm  
Hver med 1 hjulbuffer, 2 bremsede hjul  
Montagesæt, nem montage
- Mål: • bredde 920 x dybde 600 x højde 945 mm
- Bæreevne: • 90 kg, 30 kg per hylde
- Afstand mellem hylder: • 265 mm
- Vægt: • 13,4 kg
- 

Med forbehold for tekniske ændringer!

- Pak de enkelte elementer ud og bortskaf emballage.
- Kontroller, om alle elementer er med efter følgende liste.

## Levering / Elementer

Element	Antal	Navn
	3	Hylde
	2	Ramme
	2	Styreruller
	2	Bremsede hjul
	4	Hjulbuffer
	12	Monteringsbeslag
	12	Unbrakoskrue
	12	Låsemøtrik
	1	Unbrakonøgle
	1	Flad nøgle

## Montage

1. Først skal du starte med at montere hylden til rammen. Placer monteringsbeslagene i hjørnene af rammen. Skru dem fast til rammen ved hjælp af den vedlagte unbrakonøgle og flad nøgle, som findes i sættet med unbrakoskruen og møtrikken.

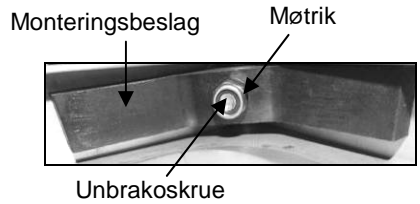

2. Læg serverings/transportvognen på siden og monter hjulbufferne. Til sidst skru 4 rullehjul til rammen.

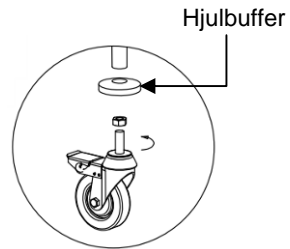

3. Anbring serverings/transportvognen forsigtigt på gulvet og sørg for, at alle fire rullehjul rører jorden. Serverings/transportvognen kan justeres ved at skru og løsne hjulene. Bestem deres placering ved hjælp af låsemøtrikker.



### **HENVISNING!**

**Fjern den beskyttende film efter montering!**

4. Når serverings/transportvognen er på det ønskede sted, lås rullehjulene ved hjælp af stopperne for at beskytte mod utilsigtet flytning eller væltning.

## Tips til rengøring

- Serverings/transportvognen skal rengøres med. en fugtig, blød klud og et mildt rengøringsmiddel.
- Brug aldrig slibende rengøringsmidler, som kan ridse vognens overflade.
- Serverings/transportvognen skal tørres med en blød klud.

## Технические данные

---











Название:	• <b>Тележка сервировочная / транспортная TS 301, с 3 уровнями</b>
Артикул:	• <b>A300073</b>
Материал:	• Хромоникелевая сталь
Материал:	• Рама: из круглых труб Ø 25,8 мм; Полка: 3, размеры каждой полки: шир. 827 x м. 510 мм 4 поворотных резиновых колеса, Ø 100 мм по 1 защите на колесе, 2 колеса с фиксаторами Раскладной комплект, простой монтаж
Размеры:	• шир. 920 x гл. 600 x гл. 490 x выс. 945 мм
Макс. допустимая нагрузка:	• 900 кг, 30 кг на полку
Расстояние между полками:	• 265 мм
Вес:	• 13,4 кг

---

Оставляем за собой возможность введения технических изменений!

- Распаковать отдельные элементы и удалить упаковочный материал.
- Проверить комплектность поставки согласно списку в следующей таблице.

**Объем поставки / Название части**

Элемент	Количество	Наименование
	3	Полка
	2	Стеллаж
	2	Поворотные колеса без фиксаторов
	2	Поворотные колеса с фиксаторами
	4	Защита колёс
	12	Крепежный угловой профиль
	12	Имбусовые винты
	12	Контргайки
	1	Шестигранный ключ
	1	Плоский рычажный ключ

## Монтаж

1. Монтаж сервировочной / транспортной тележки начинать с крепления полки к стеллажу. Вставить крепежные угловые профили от центра в углы стеллажа. Крепко привинтить их к стеллажу с помощью шестигранного ключа и плоского рычажного ключа, которые имеются в комплекте с имбусовым винтом и гайкой.

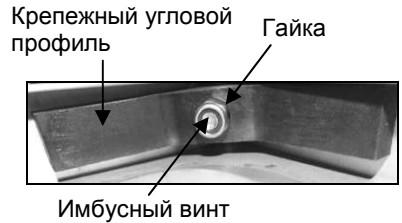

2. Положить сервировочную / транспортную тележку на сторону и прикрепить к стеллажу защиты колес. В конце ввинтить в стеллаж 4 поворотных колеса.

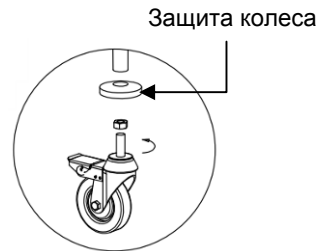

3. Осторожно поставить сервировочную / транспортную тележку на пол и удостовериться в том, что все четыре поворотных колеса касаются пола. Сервировочную / транспортную тележку можно выровнять с помощью поворотных колес, выкручивая или вкручивая их. Установить их положение с помощью защитных гаек.



### УКАЗАНИЕ!

**После монтажа снять защитную пленку!**

4. После установки сервировочной / транспортной тележки в требуемом месте заблокировать поворотные колеса (4) с помощью фиксаторов, чтобы тележка случайно не переместилась и не перевернулась.

## Рекомендации по очистке

- Сервировочную / транспортную тележку следует регулярно чистить мягкой, влажной салфеткой и чистящим средством мягкого действия.
- Ни в коем случае нельзя использовать чистящие средства, которые могут поцарапать поверхность элементов сервировочной / транспортной тележки.
- Высушить сервировочную / транспортную тележку мягкой салфеткой.



## Teknik bilgiler

---











Ürün adı:	• <b>Servis-/taşıma arabası TS 301 3 katlı</b>
Ürün no.:	• <b>A300073</b>
Malzeme:	• Krom-nikel çelik
Yapı:	• Çerçeve: yuvarlak kesitli boru; Raf: 3, boyutlar: G 827 x D 510 mm Tekerlek: Ø 100 mm, 2'si frenli, toplam 4 adet lastikli ve tamponlu dönebilir tekerlek Montaj seti, kolay montaj
Boyutlar:	• G 920 x D 600 x Y 945 mm
Maks. taşıma kapasitesi:	• 90 kg, raf başı 30 kg
Raf aralığı:	• 265 mm
Ağırlık:	• 13,4 kg

---

Teknik değişiklik hakkı mahfuzdur!

- Parçalar paketten çıkarıldıktan sonra paketleme malzemeleri uygun bir şekilde atık olarak değerlendirilmelidir.
- Aşağıdaki listeye göre teslim edilen parçaların eksiksiz olup olmadığı kontrol edilmelidir.

## Teslimata dâhil parçalar / Parça adı

Parça	Adet	Ürün adı
	3	Raf
	2	İskelet
	2	Frensiz dönebilir tekerlek
	2	Frenli dönebilir tekerlek
	4	Tampon
	12	Sabitleme braketi
	12	Alyan vida
	12	Kontra somun
	1	Alyan
	1	Düz anahtar

## Montaj

1. Servis/taşıma arabasının montajı, rafı çerçeveye monte ederek başlanmalıdır. Çerçeve köşelerinin iç tarafına sabitleme braketi monte edildikten sonra; Alyan vida ile somun seti ve Alyan anahtar ile düz anahtar kullanarak sıkı bir şekilde çerçeveye sabitlenmelidir.

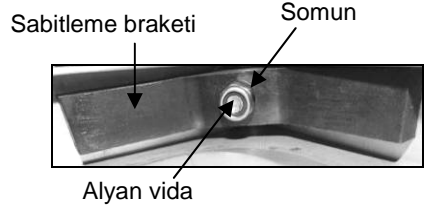

2. Servis/taşıma arabası yana yatırılmalı ve tekerlek tamponları çerçeveye monte edilmelidir. Son olarak 4 adet döner tekerlek çerçeveye monte edilmelidir.

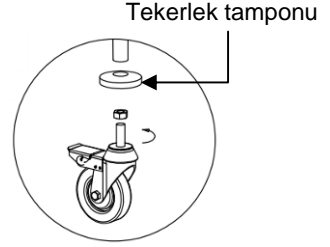

3. Servis/taşıma arabası dikkatli bir şekilde zemine yerleştirilip dört tekerleğin zemine değdiğinden emin olunmalıdır. Servis/taşıma arabasının sabitliği döner tekerlekler döndürülerek sağlanmalı, somunlar sıkılarak sabitlenmelidir.



### **DİREKTİF!**

**Montajdan sonra koruma filmi çıkartılmalıdır!**

4. Servis/taşıma arabası istenen yere yerleştirildikten sonra, yerinin değişmesi veya devrilmesini önlemek için; döner tekerlekler fren ile bloke edilmelidir.

## Temizlik talimatları

- Servis/taşıma arabası nemli, yumuşak bez ve aşındırıcı olmayan temizlik malzemeleri ile düzenli olarak temizlenmelidir.
- Servis/taşıma arabasının ve parçalarının yüzeylerine zarar verebilecek aşındırıcı temizlik malzemeleri kesinlikle kullanılmamalıdır.
- Servis/taşıma arabası yumuşak bez ile kurutulmalıdır.

## Dane techniczne

---











Nazwa:	<ul style="list-style-type: none"><li>• <b>Wózek kelnerski-/transportowy TS 301 z 3 poziomami</b></li></ul>
Nr art.:	<ul style="list-style-type: none"><li>• <b>A300073</b></li></ul>
Materiał:	<ul style="list-style-type: none"><li>• Stal chromowo-niklowa</li></ul>
Wykonanie:	<ul style="list-style-type: none"><li>• Rama: z rur okrągłych Ø 25,8 mm; Półka: 3, wymiary każdej półki: szer. 827 x gł. 510 mm 4 gumowe kółka skrętne, Ø 100 mm po 1 odboju, 2 kółka skrętne ze stoperami Zestaw do składania, łatwy montaż</li></ul>
Wymiary:	<ul style="list-style-type: none"><li>• szer. 920 x gł. 600 x wys. 945 mm</li></ul>
Nośność maks.:	<ul style="list-style-type: none"><li>• 90 kg, 30 kg na półkę</li></ul>
Odstęp pomiędzy półkami:	<ul style="list-style-type: none"><li>• 265 mm</li></ul>
Waga:	<ul style="list-style-type: none"><li>• 13,4 kg</li></ul>

---

Zastrzega się możliwość wprowadzania zmian technicznych!

- Rozpakować pojedyncze elementy i zutilizować materiał opakowaniowy.
- Sprawdzić kompletność dostawy na podstawie poniższej listy.

**Zakres dostawy / Nazwy części**

Element	Ilość	Nazwa
	3	Półka
	2	Stelaż
	2	Kółka skrętne bez stoperów
	2	Kółka skrętne ze stoperami
	4	Odbojnik kółka
	12	Kątownik mocujący
	12	Śruby imbusowe
	12	Nakrętka kontruująca
	1	Klucz imbusowy
	1	Klucz szczękowy płaski

## Montaż

1. Montaż wózka kelnerskiego/transportowego rozpocząć od mocowania półki do stelaża. Włożyć kątowniki mocujące od środka w rogi stelaża. Przykręcić je mocno do stelaża za pomocą klucza imbusowego i klucza szcękowego płaskiego, znajdującą się w zestawie śrubką imbusową i nakrętką.

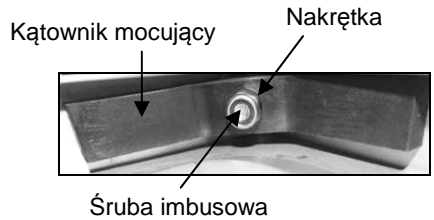

2. Położyć wózek kelnerski/transportowy na boku i zamocować do stelaża odbojnik kółek. Na koniec wkręcić 4 kółka skrętne do stelaża.

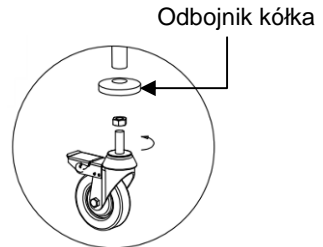

3. Postawić wózek kelnerski/transportowy ostrożnie na podłodze i upewnić się, że wszystkie cztery kółka skrętne dotykają podłogę. Wózek kelnerski/transportowy można wy poziomować za pomocą kółek skrętnych wykręcając je lub wkręcając. Ustalić ich położenie przy pomocy nakrętek zabezpieczających.



### **WSKAZÓWKA!**

**Po montażu usunąć folię ochronną!**

4. Po ustawieniu wózka kelnerskiego/transportowego w żądanym miejscu, zablokować kółka skrętne przy pomocy stoperów, aby wózek kelnerski/transportowy nie został przypadkowo przesunięty lub przewrócony.

## Wskazówki dotyczące czyszczenia

- Wózek kelnerski/transportowy należy czyścić regularnie wilgotną, miękką ściereczką i łagodnym środkiem czyszczącym.
- Nie wolno w żadnym przypadku stosować środków czyszczących, które mogą porysować powierzchnię elementów wózka kelnerskiego/transportowego.
- Osuszyć wózek transportowo/kelnerski miękką ściereczką.



## Technické údaje

---











Název:	• <b>Servírovací-/transportní vozík TS 301 se 3 úrovněmi</b>
Č. výr.:	• <b>A300073</b>
Materiál:	• Chromniklová ocel
Provedení:	• Rám: z kulatých trubek Ø 25,8 mm; Police: 3, rozměry každé police: š 827 x h 510 mm 4 pryžová otočná kolečka, Ø 100 mm s 1 nárazníkem, 2 otočná kolečka s brzdami Stavebnicový systém, snadná montáž
Rozměry:	• š 920 x h 600 x v 945 mm
Max. únosnost:	• 90 kg, 30 kg na polici
Rozestup mezi policemi:	• 265 mm
Hmotnost:	• 13,4 kg

---

Technické změny vyhrazeny!

- Vybalte jednotlivé díly a ekologicky zlikvidujte obalový materiál.
- Zkontrolujte úplnost dodávky podle níže uvedeného seznamu.

**Rozsah dodávky / Název dílů**

Díl	Počet	Název
	3	Police
	2	Bočnice
	2	Otočná kolečka bez brzdy
	2	Otočná kolečka s brzdou
	4	Nárazník kolečka
	12	Upevňovací úhelník
	12	Imbusové šrouby
	12	Kontramatka
	1	Imbusový klíč
	1	Plochý klíč

## Montáž

1. Montáž servírovacího/transportního vozíku začněte připevněním polic k bočnicím. Upevňovací úhelníky umístěte z vnější strany do rohů polic. Přišroubujte pevně imbusovým klíčem společně s imbusovými šrouby a maticemi na bočnicích.

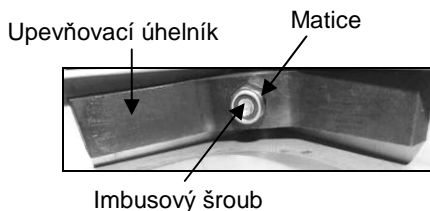

2. Servírovací/transportní vozík položte na bok a na bočnice připevněte nárazníky koleček. Na závěr zašroubujte do bočnic 4 otočná kolečka.

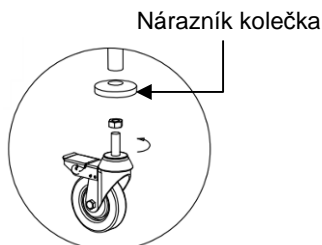

3. Servírovací/transportní vozík postavte opatrně na podlahu a ujistěte se, že se všechna čtyři otočná kolečka dotýkají podlahy. Servírovací/transportní vozík můžete vyrovnat do roviny pomocí otočných koleček tak, že je zašroubujete nebo vyšroubujete. Jejich polohu zajistíte kontramatkami.



### **POKYN!**

**Po montáži odstraňte ochrannou fólii!**

4. Po postavení servírovacího/transportního vozíku na požadované místo zabrzděte otočná kolečka, aby se servírovací/transportní vozík nedopatřením nepřesunul nebo nepřevrátil.

## **Pokyny k čištění**

- Servírovací/transportní vozík čistíte pravidelně vlhkým, měkkým hadříkem a jemným čisticím prostředkem.
- Nikdy nepoužívejte abrazivní čisticí prostředky, které by mohly poškrábat povrch servírovacího/transportního vozíku.
- Servírovací/transportní vozík osušte měkkým hadříkem.

## Tehnički podaci

---











Naziv:	<ul style="list-style-type: none"><li>• <b>Transportna kolica za konobare TS 301 za 3 police</b></li></ul>
Br. art.:	<ul style="list-style-type: none"><li>• <b>A300073</b></li></ul>
Materijal:	<ul style="list-style-type: none"><li>• Krom-nikal čelik</li></ul>
Izvedba:	<ul style="list-style-type: none"><li>• Okvir: od okruglih profila Ø 25,8 mm; Police: 3, dimenzije svake police: Š. 827 x D. 510 mm 4 gumena okretna kotača, Ø 100 mm svaki s po 1 odbojnik kotača, 2 okretna kotača sa kočnicama Komplet za samostalno sastavljanje, jednostavna montaža</li></ul>
Dimenzije:	<ul style="list-style-type: none"><li>• Š. 920 x D. 600 x V. 945 mm</li></ul>
Max. nosivost:	<ul style="list-style-type: none"><li>• 90 kg, 30 kg po polici</li></ul>
Razmak između polica:	<ul style="list-style-type: none"><li>• 265 mm</li></ul>
Težina:	<ul style="list-style-type: none"><li>• 13,4 kg</li></ul>

---

Pridržavamo pravo na uvođenje tehničkih promjena!

- Otpakirajte pojedinačne elemente uređaja i zbrinite pakirni materijal.
- Na osnovi sljedećeg popisa provjerite je li isporuka kompletna.

**Opseg isporuke / Naziv elementa**

Element	Količina	Naziv
	3	Polica
	2	Nosač
	2	Okretni kotači bez kočnica
	2	Okretni kotači sa kočnicama
	4	Odbojnik za kotač
	12	Kutna spojnica
	12	Imbus vijci
	12	Kontra matica
	1	Imbus ključ
	1	Plosnati čeljusni ključ

## Montaža

1. Na početku montaže transportnih kolica za konobare policu pričvrstite do nosača. Kutne spojnice stavite u unutarnje uglove nosača. Čvrsto ih stegnite pomoću imbus ključa i plosnatog čeljusnog ključa koristeći isporučene imbus vijke i matice.

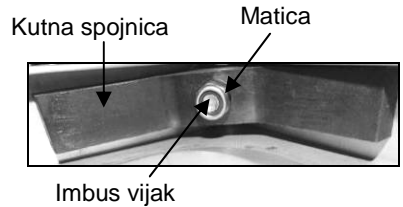

2. Transportna kolica za konobare postavite na bok i do nosača pričvrstite odbojnik za kotače. Nakon toga 4 okretna kotača spojite sa nosačem.

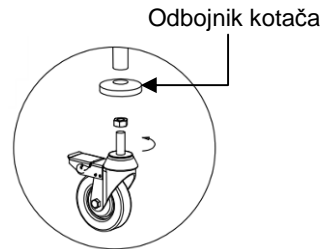

3. Transportna kolica za konobare oprezno postavite na pod i provjerite da li sva četiri okretna kotača dodiruju podlogu. Transportna kolica za konobare nivelirajte pomoću okretnih kotača postupkom uvijanja ili odvijanja. Odredite njihov položaj pomoću sigurnosnih matica.



### **NAPOMENA!**

**Nakon montaže odstranite zaštitnu foliju!**

4. Nakon što transportna kolica za konobare postavite na željeno mjesto, blokirajte okretna kotača pomoću kočnica kako biste spriječili slučajno pomicanje ili prevrtanja kolica.

## **Napomene vezane za čišćenje**

- Transportna kolica za konobare redovito čistite mekanom vlažnom krpicom i blagim deterdžentom.
- Nikada ne koristite abrazivna sredstva za čišćenje koja bi mogla ogrebatu površinu elemenata kolica.
- Transportna kolica za konobare osušite pomoću mekane krpice.



## Műszaki adatok

---











Megnevezés:	<ul style="list-style-type: none"><li>• <b>Tálaló-/szállító kocsi TS 301 3 szintes</b></li></ul>
Cikkszám:	<ul style="list-style-type: none"><li>• <b>A300073</b></li></ul>
Anyaga:	<ul style="list-style-type: none"><li>• Krómnikkelacél 18/10</li></ul>
Kivitelezés:	<ul style="list-style-type: none"><li>• keret: cső idom Ø 25,8 mm; Polc: 3, polcok mérete: szél. 827 x mély. 510 mm 4 gumikerekes, Ø 100 mm 1 átmérőben, 2 fékezett bolygókerék összeszerelő készlet, egyszerű összeszerelés</li></ul>
Méretek:	<ul style="list-style-type: none"><li>• Sz. 920 x mély. 600 x mag. 945 mm</li></ul>
Max. terhelhetőség:	<ul style="list-style-type: none"><li>• 90 kg, 30 kg polconként</li></ul>
Polcok közötti távolság:	<ul style="list-style-type: none"><li>• 265 mm</li></ul>
Súly:	<ul style="list-style-type: none"><li>• 13,4 kg</li></ul>

---

A műszaki adatok változtatásának jogát fenntartjuk!

- Csomagolja ki az egyes elemeket, és a csomagolóanyagot semmisítse meg.
- Ellenőrizze a szállított készlet tartalmát az alábbi lista szerint.

**Szállított készlet / Részek megnevezése**

Részegység	Darab	Megnevezés
	3	Polc
	2	Keret
	2	Nem fékezett bolygókerék
	2	Fékezhető bolygókerék
	4	Kerék rögzítő
	12	Rögzítő elem
	12	Imbusz csavar
	12	Kontra anya
	1	Imbuszkulcs
	1	Villáskulcs

## Összeszerelés

1. A tálaló/szállító kocsi összeszerelését a polc keretre való rögzítésével.  
Helyezze a rögzítő elemeket belülről a keret sarkaiba. Csavarozza erősen a keretre az imbuszkulcs és a villáskulcs, illetve a készletben megtalálható imbusz csavar és anya segítségével.

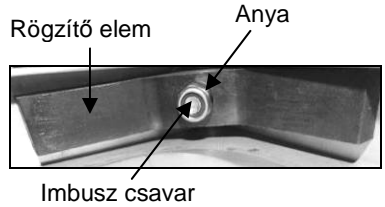

2. Helyezze a tálaló/szállító kocsit az oldalára, és rögzítse a kerethez a kerék rögzítőt. Végül tekerje be a 4 bolygókeretet a keretbe.

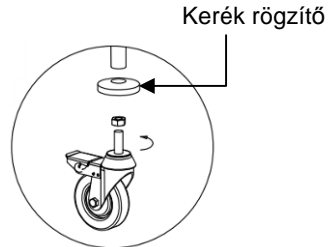

3. Állítsa a tálalószállító kocsit óvatosan a padlóra, és bizonyosodjon meg, hogy mind a 4 bolygókerék érinti a padlót. A tálaló/szállító kocsit vízszintezheti a bolygókerékek kitekéréseivel, betekerésével. Állítsa be a helyzetüket a biztosító anya segítségével.



### JÓ TANÁCS!

**Összeszerelés után távolítsa el a védőfóliát!**

4. A tálaló/szállító kocsi kívánt helyre állítását követően, rögzítse a bolygókerékeket a fék segítségével, hogy a tálaló/szállító kocsi ne tudjon véletlenül elgurulni, vagy elfordulni.

## Tisztítási tanácsok

- A tálaló/szállító kocsit rendszeresen, puha és nedves törölkendővel, enyhe tisztítószerrel ajánlott tisztítani.
- Semmilyen esetben ne használjon súroló tisztítóanyagot, mert ezek megkarcolhatják a tálaló/szállító kocsi felületét.
- Szárítsa meg a tálaló/szállító kocsit puha törölkendővel.

## Τεχνικά στοιχεία

---











Όνομασία:	<ul style="list-style-type: none"> <li>• <b>Τρόλεϊ σερβιρίσματος-/μεταφοράς TS 301 3 επιπέδων</b></li> </ul>
Κωδ. είδους:	<ul style="list-style-type: none"> <li>• <b>A300073</b></li> </ul>
Υλικό:	<ul style="list-style-type: none"> <li>• Χρωμονικελιούχος χάλυβας 18/10</li> </ul>
Κατασκευή:	<ul style="list-style-type: none"> <li>• Πλαίσιο από σωλήνα στρογγυλής διατομής Ø 25,8 mm, Ράφι: 3 διαστάσεις του κάθε ραφιού. πλάτος 827 x βάθος 510 mm 4 λαστιχένιες ρόδες διεύθυνσης, Ø 100 mm Έκαστη με 1 αποσβεστήρα πρόσκρουσης, 2 σταθερές ρόδες Έτοιμο κιτ, εύκολη συναρμολόγηση</li> </ul>
Διαστάσεις:	<ul style="list-style-type: none"> <li>• πλάτος 920 x βάθος 600 x ύψος 945 mm</li> </ul>
Μέγιστη φέρουσα ικανότητα:	<ul style="list-style-type: none"> <li>• 90 kg, 30 kg ανά ράφι</li> </ul>
Απόσταση ανάμεσα στα ράφια:	<ul style="list-style-type: none"> <li>• 265 mm</li> </ul>
Βάρος:	<ul style="list-style-type: none"> <li>• 13,4 kg</li> </ul>

---

Διατηρείται δικαίωμα τεχνικών τροποποιήσεων!

- Αφαιρέστε τη συσκευασία από τα μεμονωμένα εξαρτήματα και απόρριψη του υλικού της.
- Ελέγξτε την πληρότητα της παράδοσης με βάση την ακόλουθη λίστα.

## Υλικά παράδοσης / Ονομασία εξαρτήματος

Εξάρτημα	Ποσότητα	Ονομασία
	3	Ράφι
	2	Πλαίσιο
	2	Ρόδες διεύθυνσης
	2	Σταθερές ρόδες
	4	Αποσβεστήρας πρόσκρουσης για ρόδα
	12	Γωνία στήριξης
	12	Εξάγωνες βίδες
	12	Κόντρα περικόχλιο
	1	Εξάγωνο κλειδί
	1	Επίπεδο κλειδί περικοχλίων

## Συναρμολόγηση

1. Ξεκινήστε τη συναρμολόγηση του τρόλεϊ σερβιρίσματος από την εγκατάσταση του ραφιού στο πλαίσιο.  
Τοποθετήστε τις γωνίες στήριξης από μέσα στις γωνίες του πλαισίου. Βιδώστε τις δυνατά στο πλαίσιο με το εξάγωνο κλειδί και το κλειδί περικοχλίων, τα οποία βρίσκονται στο σετ με εξάγωνη βίδα και περικόχλιο.

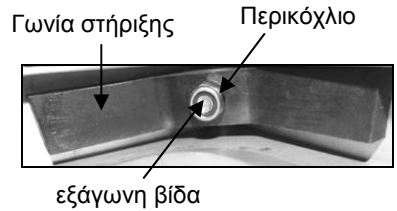

2. Τοποθετήστε το τρόλεϊ στη μια πλευρά του και εγκαταστήστε στο πλαίσιο τους αποσβεστήρες πρόσκρουσης για ρόδες. Τέλος, βιδώστε τις 4 ρόδες στα πλευρικά τμήματα.

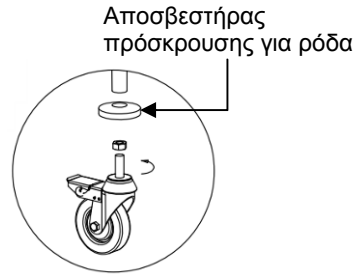

3. Τοποθετήστε το τρόλεϊ σερβιρίσματος με προσοχή στο πάτωμα και βεβαιωθείτε ότι όλες οι τέσσερις ρόδες αγγίζουν το έδαφος. Το τρόλεϊ σερβιρίσματος μπορεί να οριζοντιωθεί με τη χρήση των ρόδων, με το βίδωμα ή ξεβίδωμά τους. Καθορίστε τη θέση τους με το περικόχλιο ασφάλειας.



### ΟΔΗΓΙΑ!

**Μετά τη συναρμολόγηση αφαιρέστε την προστατευτική μεμβράνη!**

4. Μετά την τοποθέτηση του τρόλεϊ στην επιθυμητή θέση, πρέπει να μπλοκάρете 2 ρόδες έτσι ώστε το τρόλεϊ να μη μετακινηθεί τυχαία αλλού ή να μην ανατραπεί.

## Οδηγίες καθαρισμού

- Το τρόλεϊ σερβιρίσματος πρέπει να καθαρίζεται τακτικά με ένα μαλακό, υγρό πανί και ήπιο απορρυπαντικό.
- Σε καμία περίπτωση δεν επιτρέπεται να χρησιμοποιούνται καθαριστικές ουσίες που μπορεί να γρατζουνίσουν την επιφάνεια των εξαρτημάτων του τρόλεϊ σερβιρίσματος.
- Στεγνώστε το τρόλεϊ σερβιρίσματος με ένα μαλακό πανί.